

SHB010~030

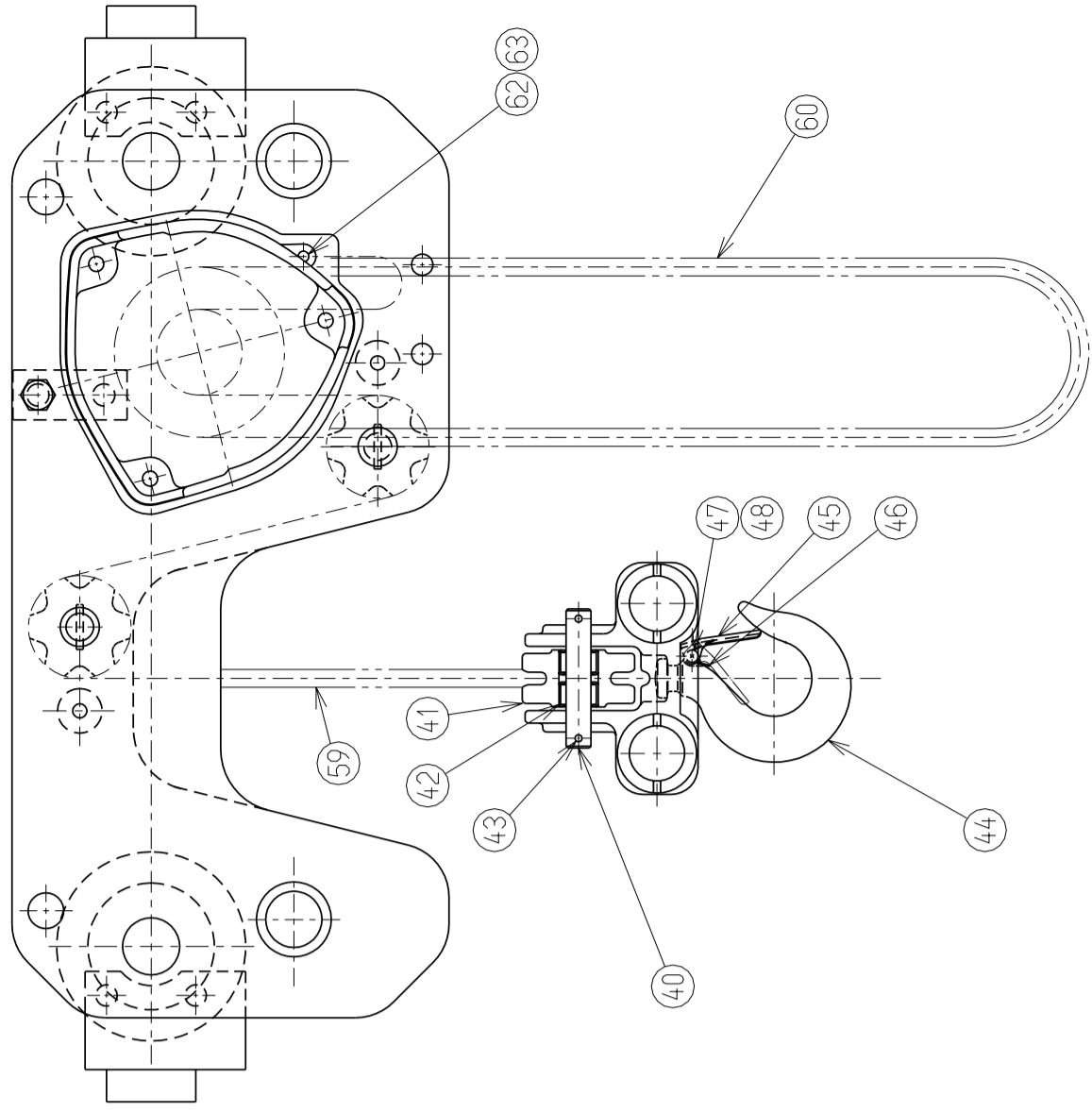

SHB010~030 with chain container

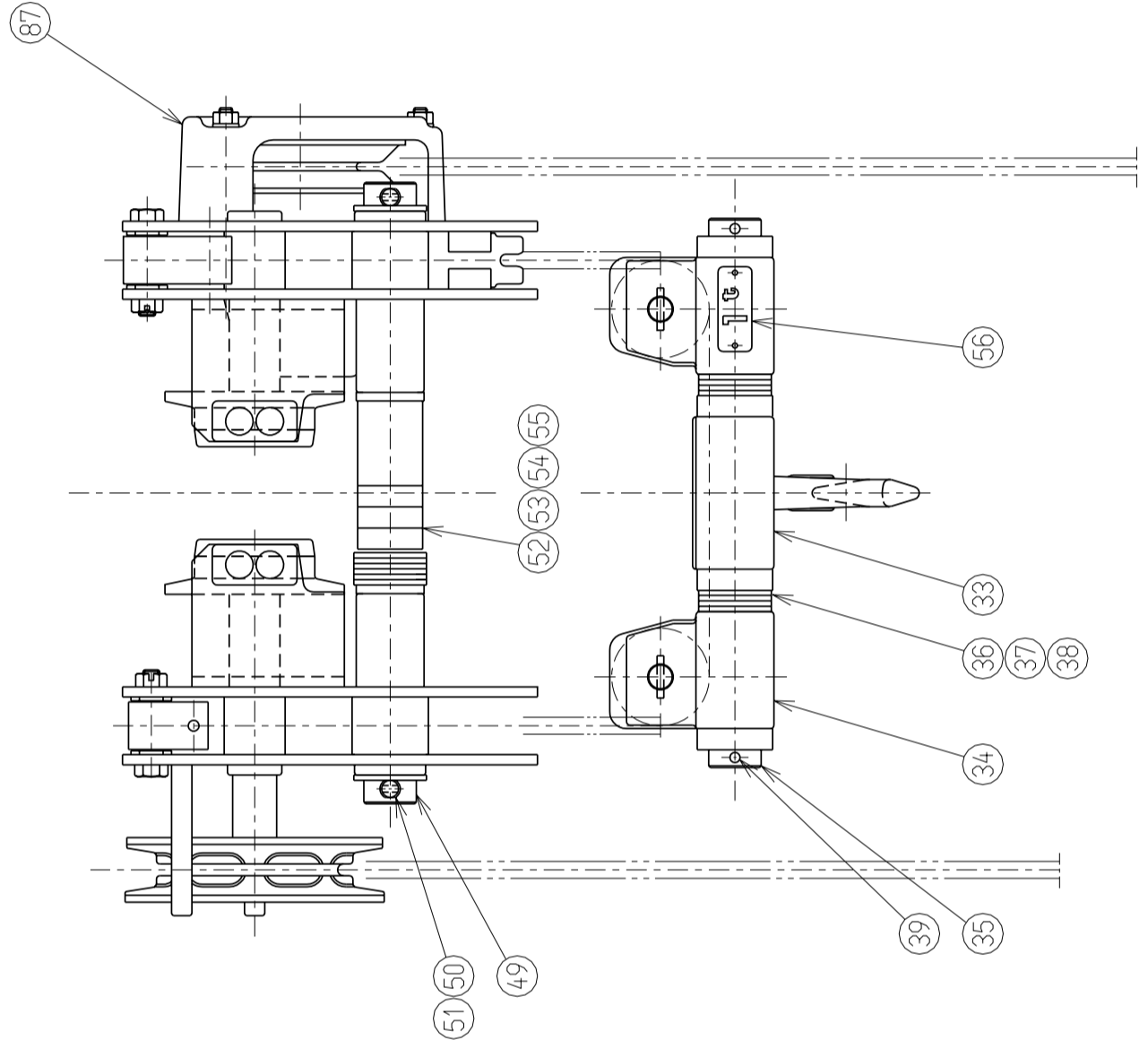
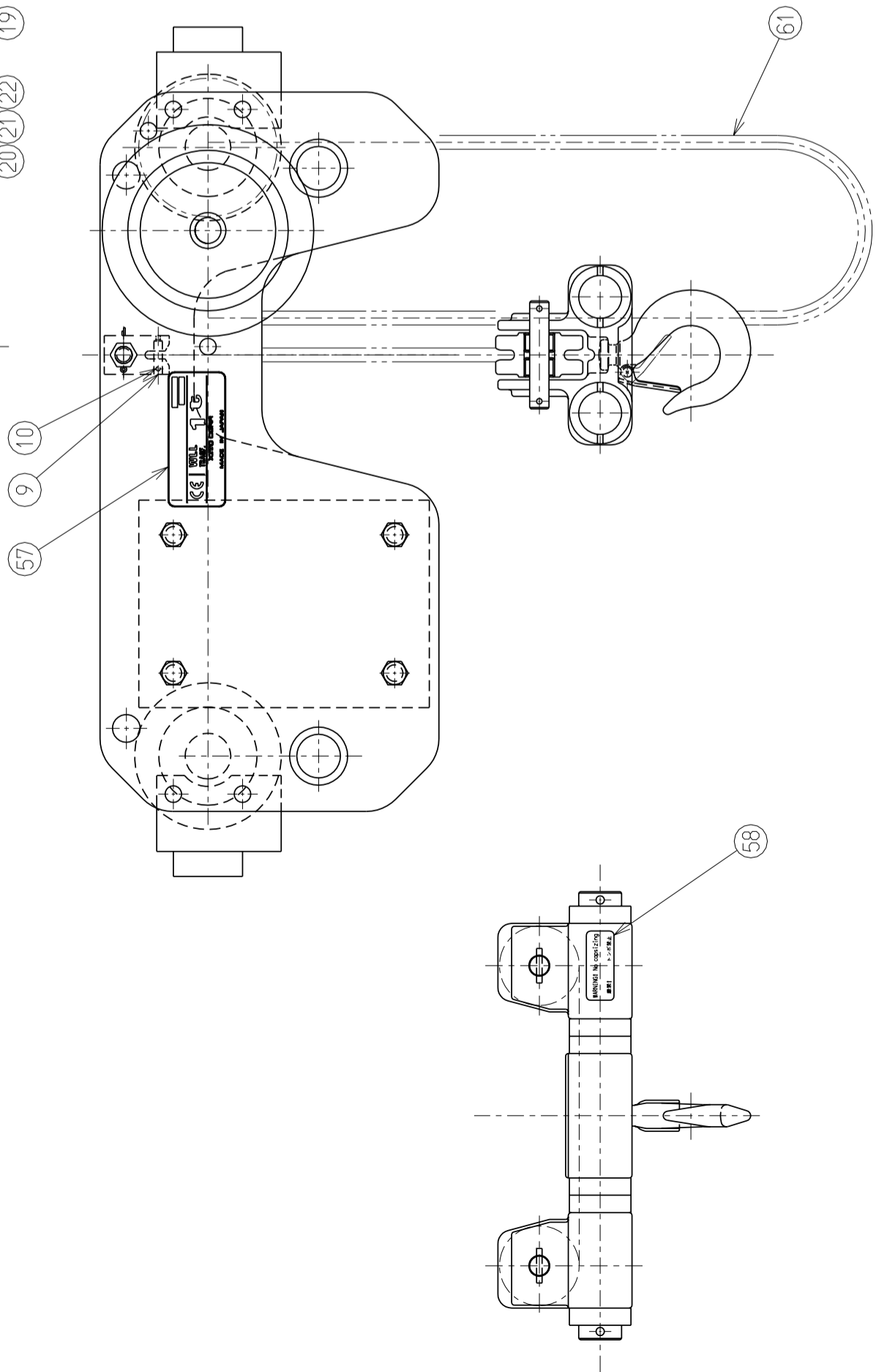
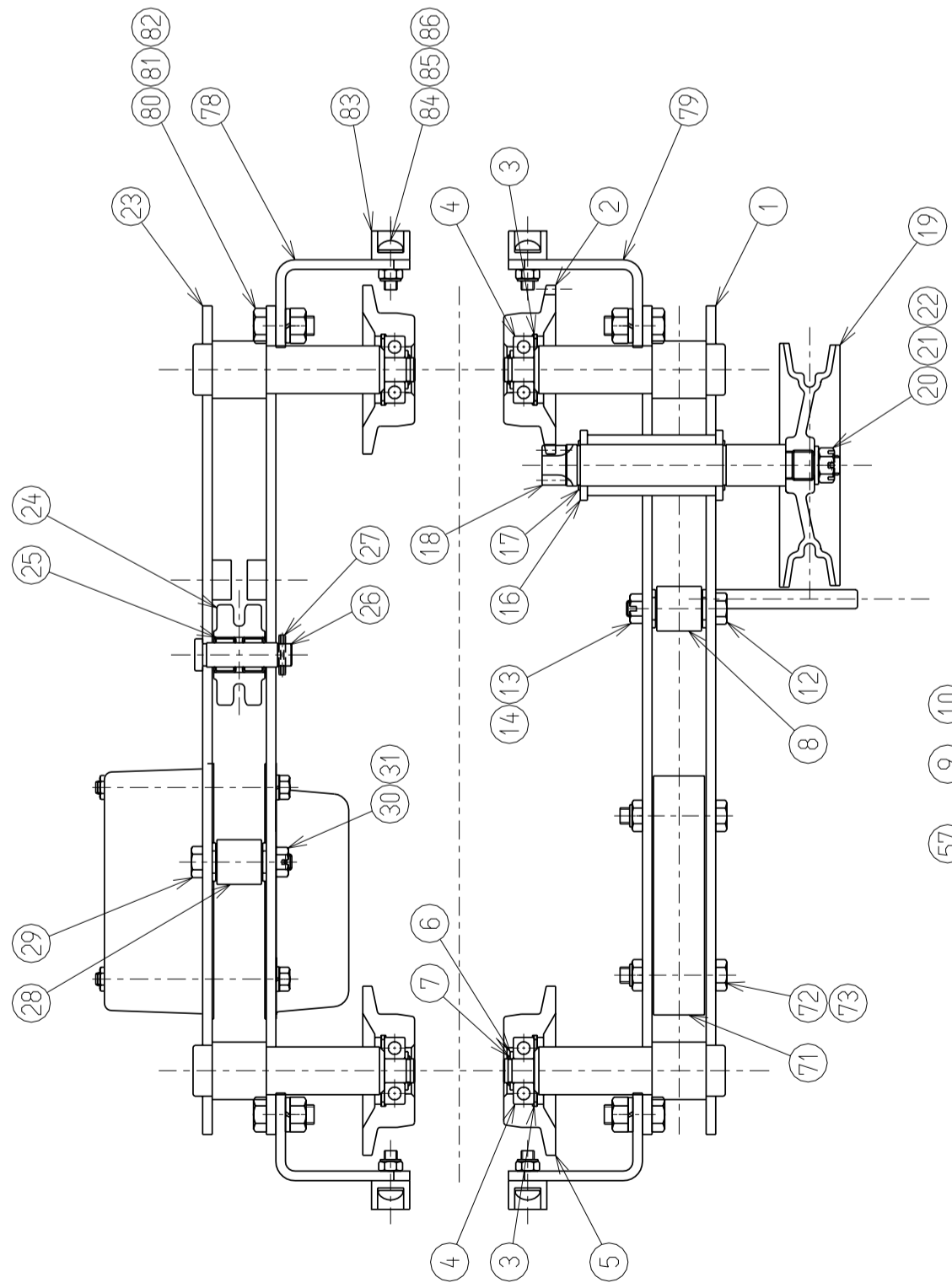
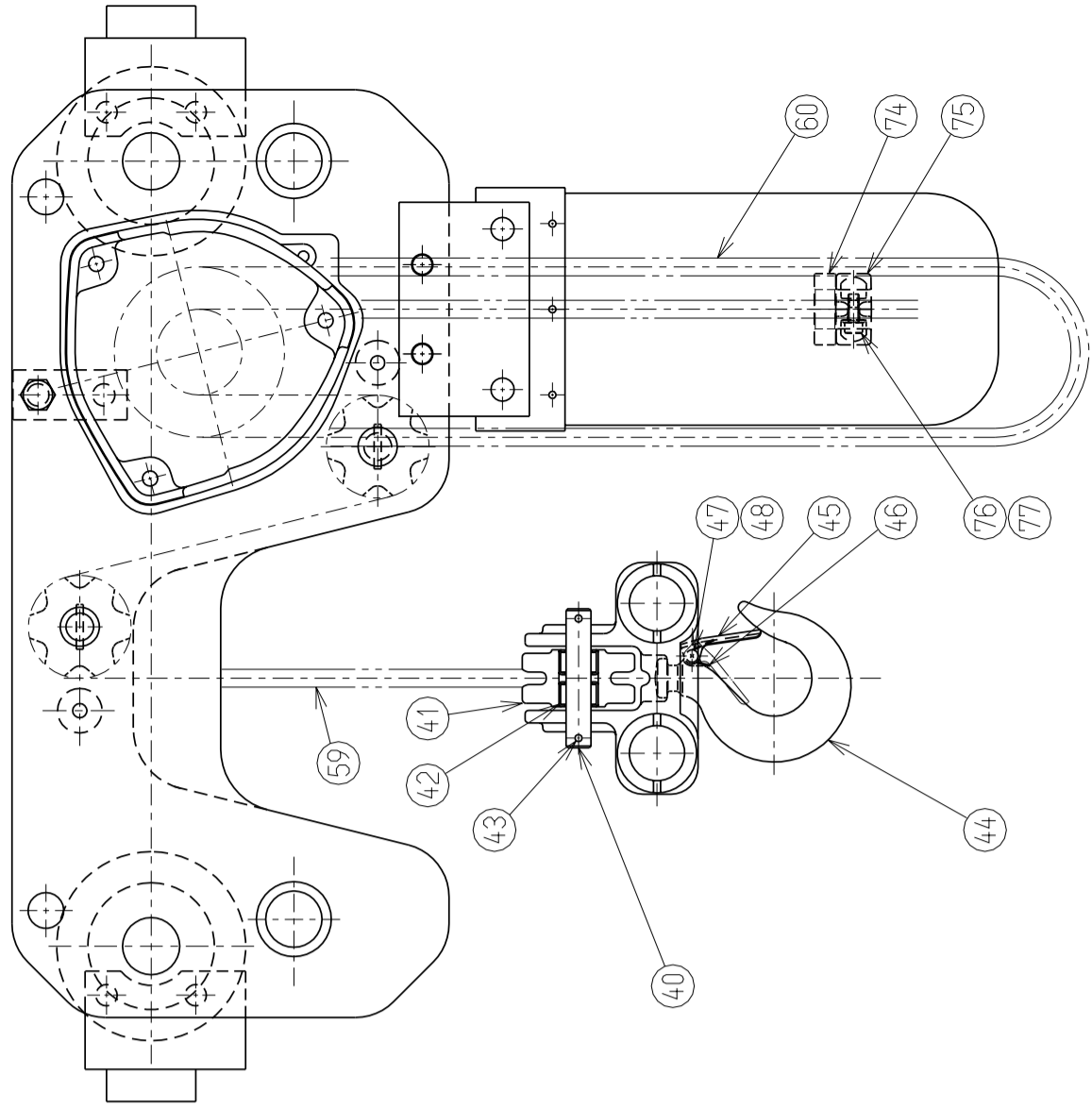
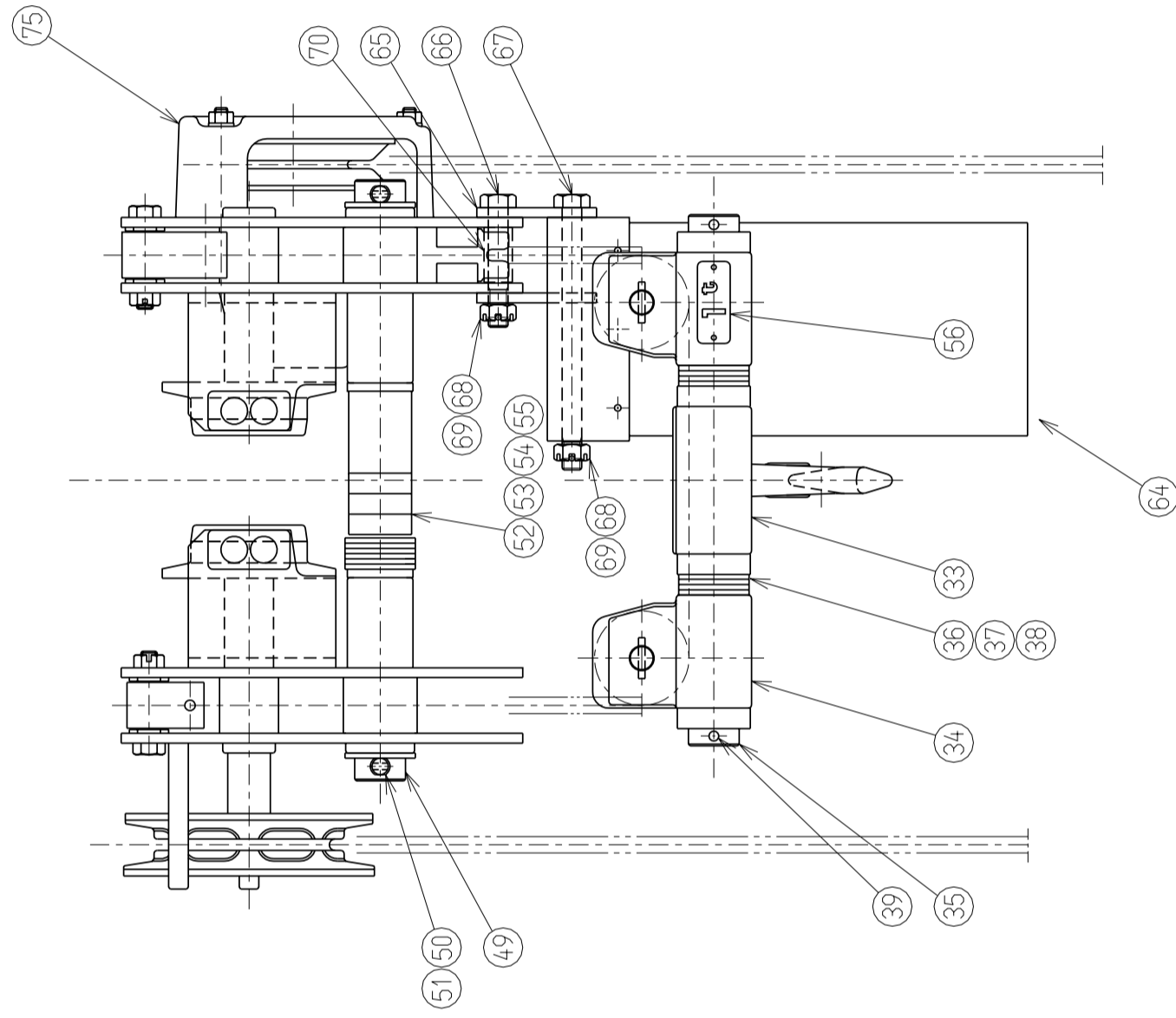
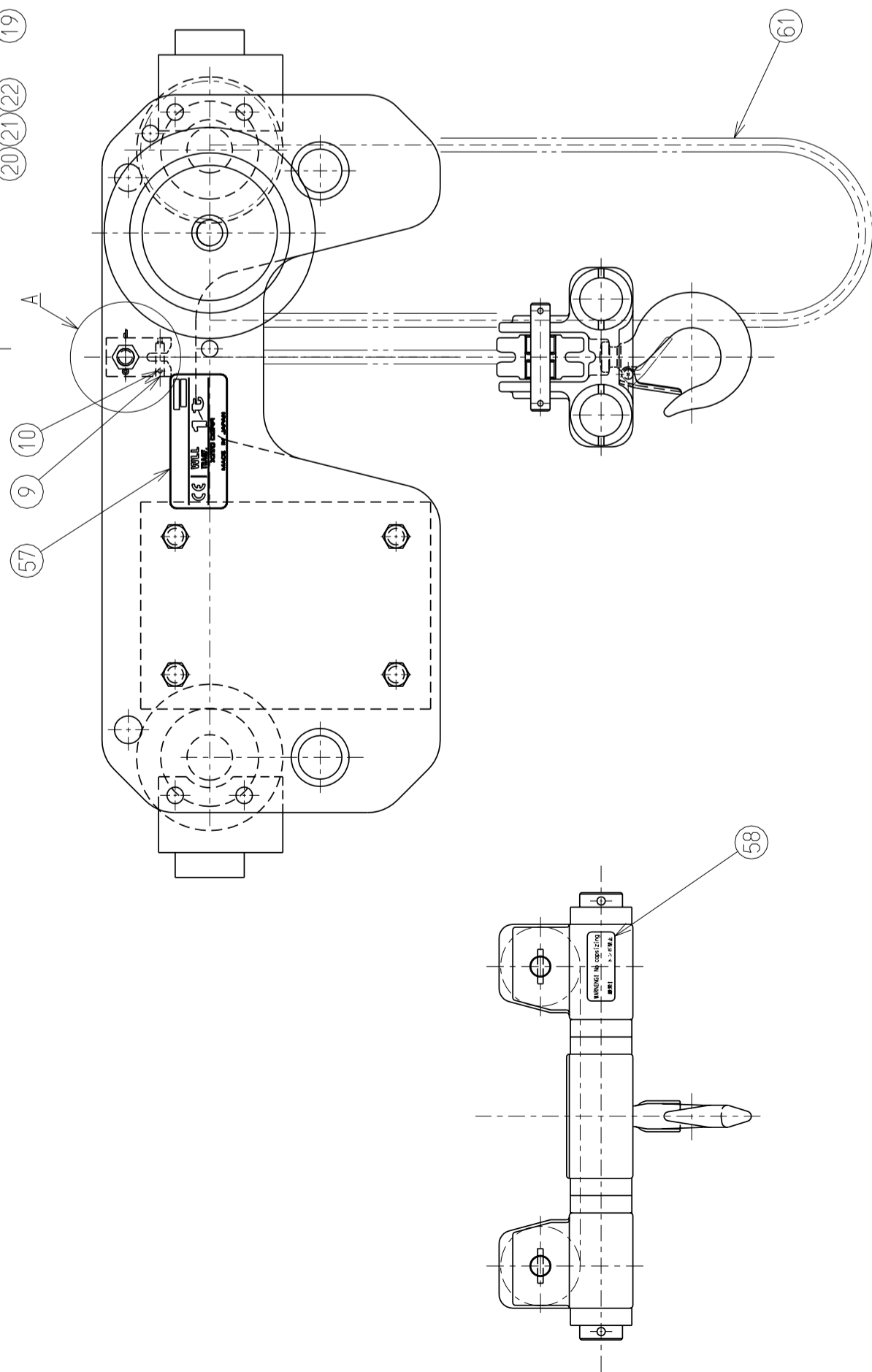
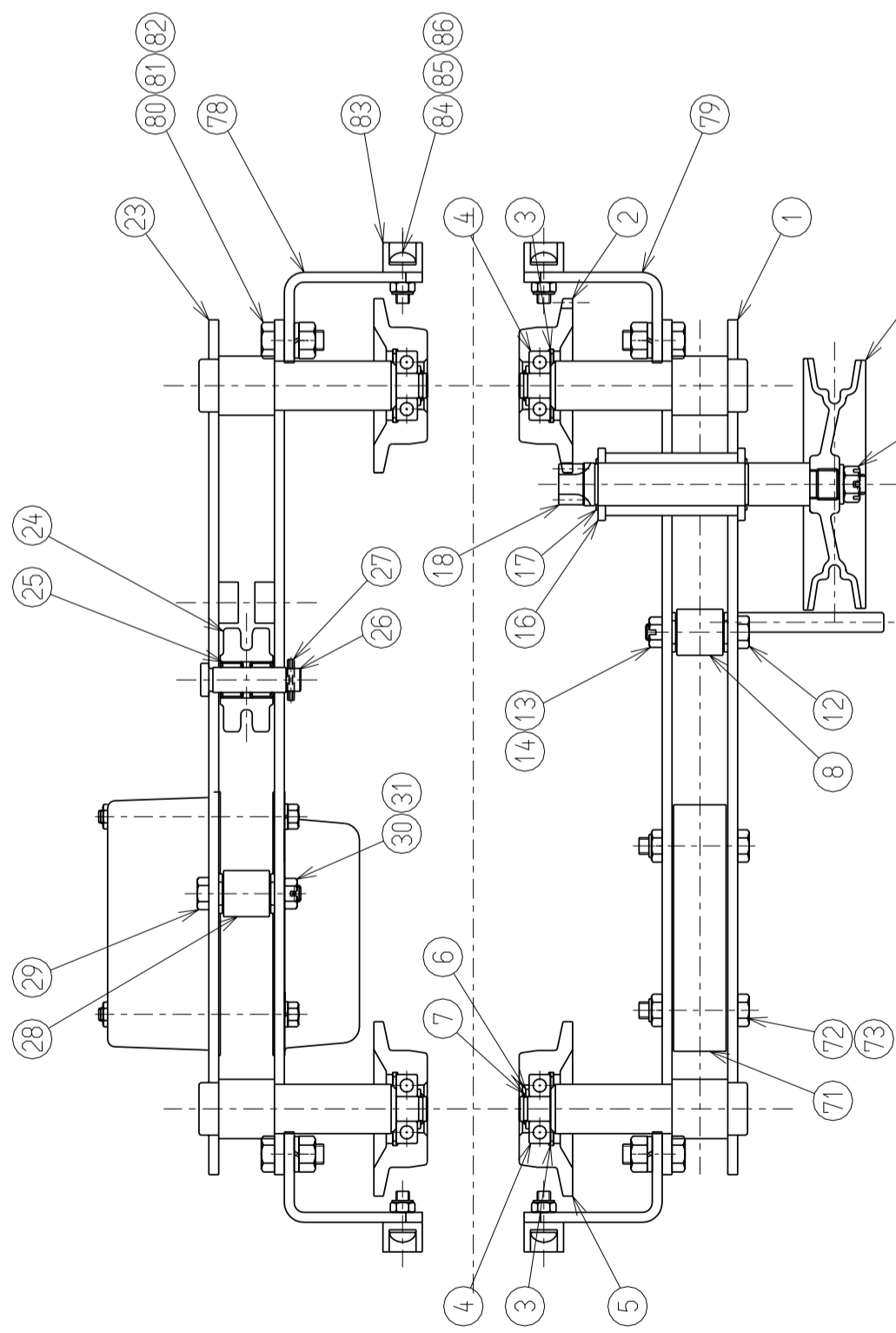

SHB050

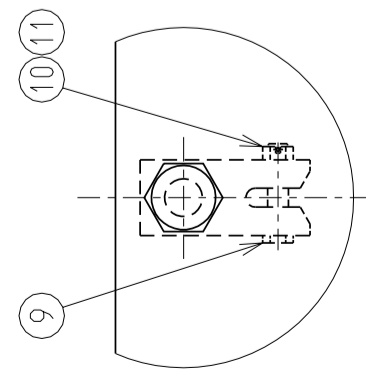
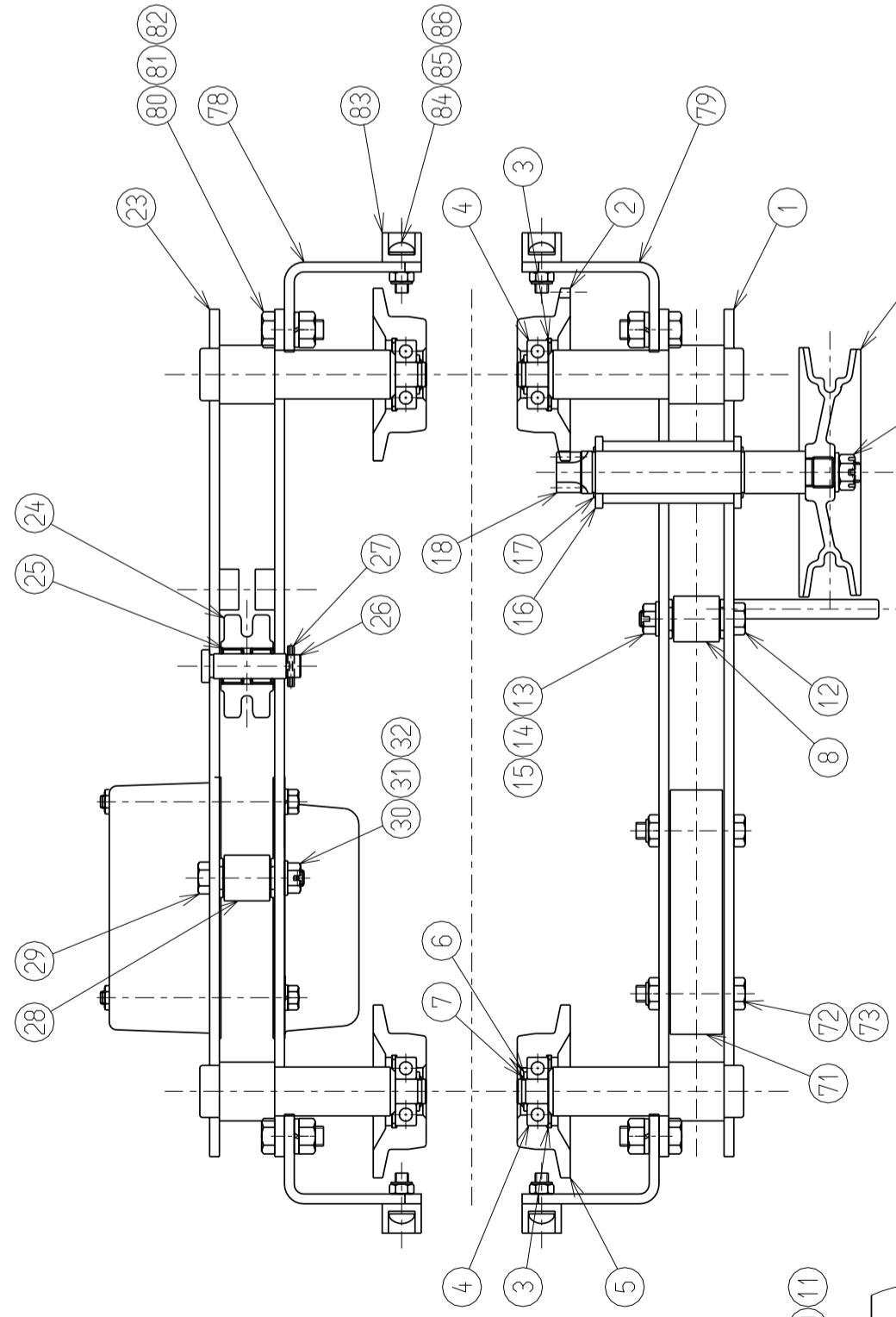

Section A

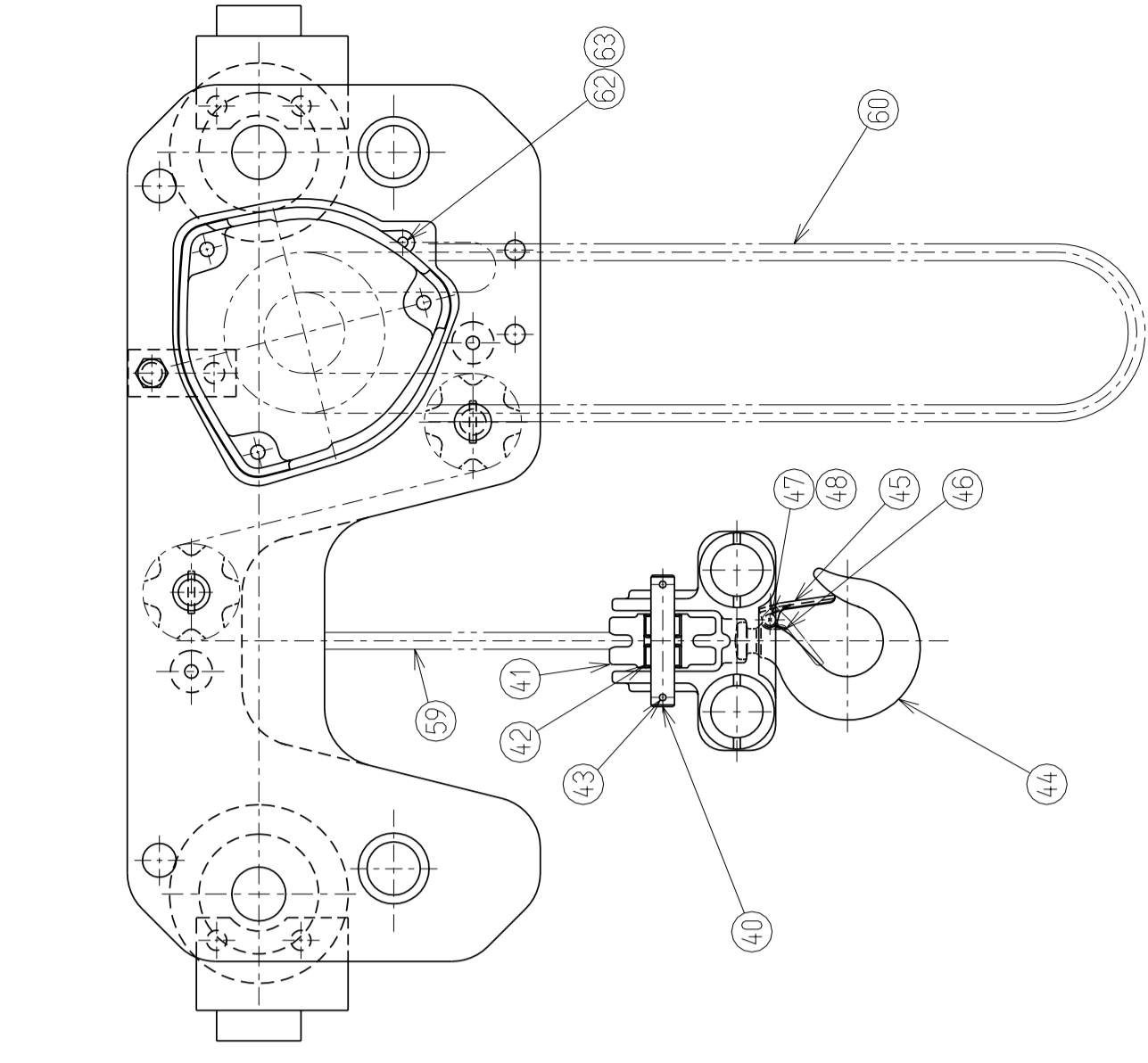
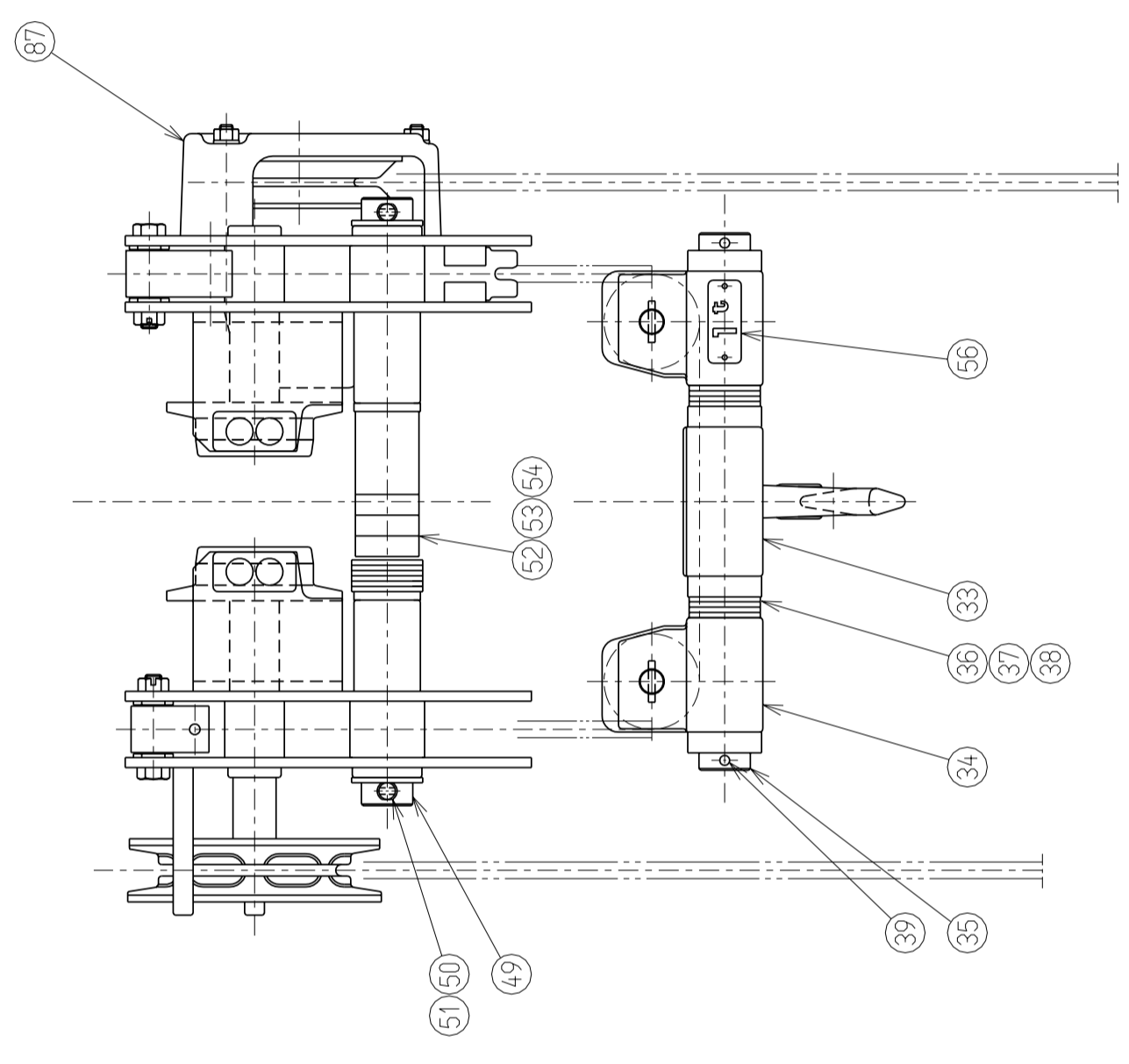

SHB050 with chain container

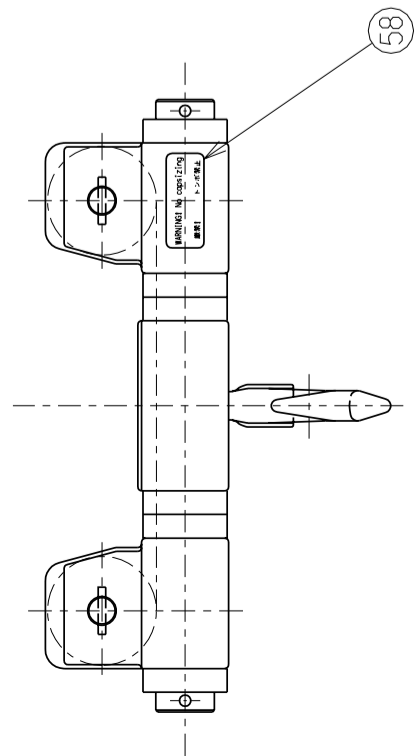
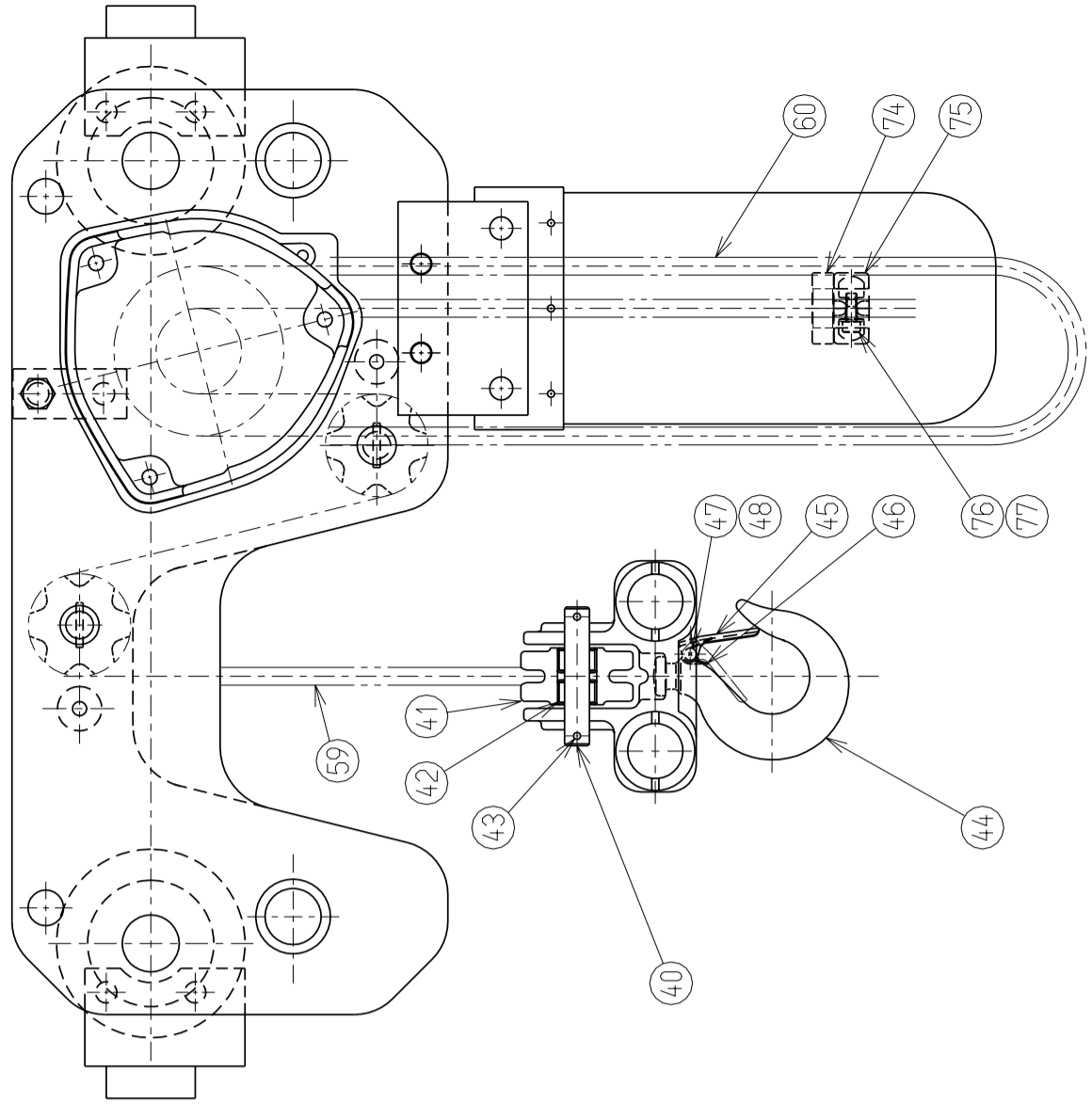
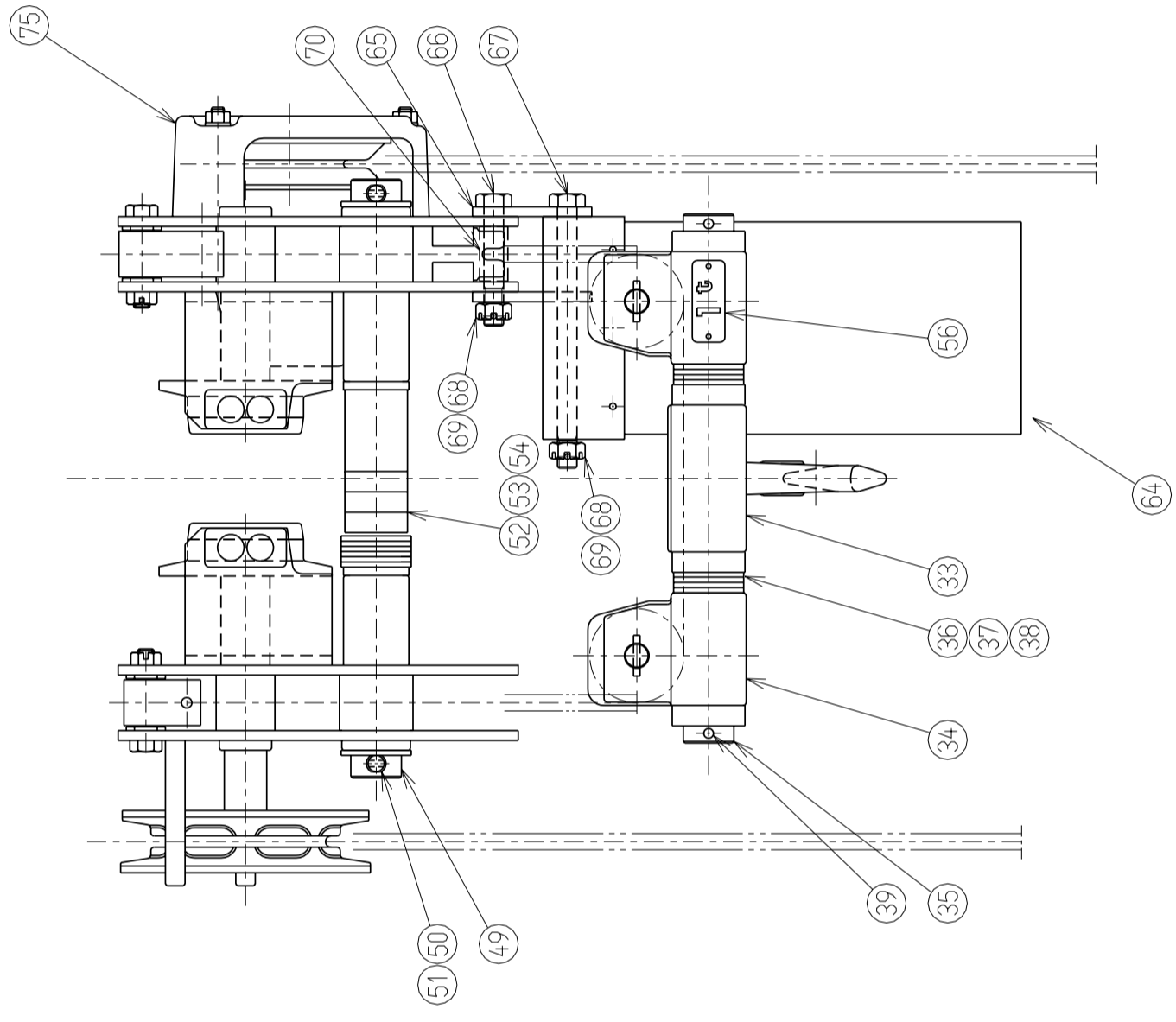
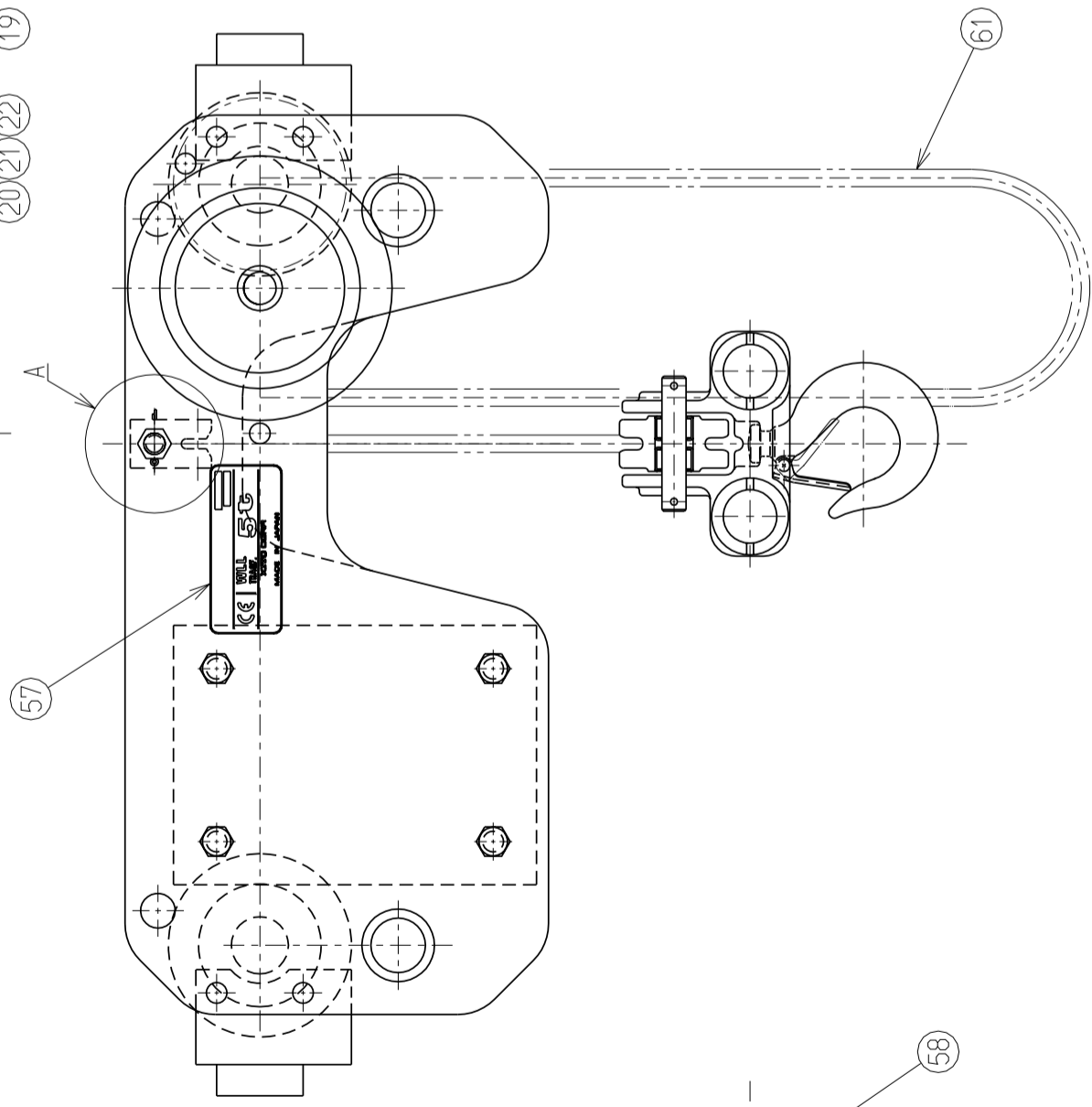
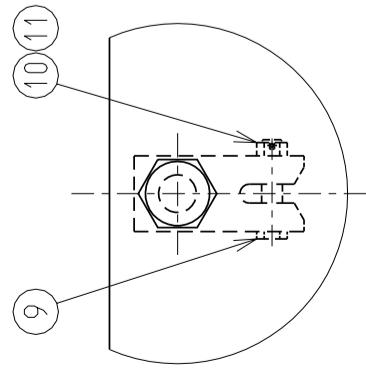
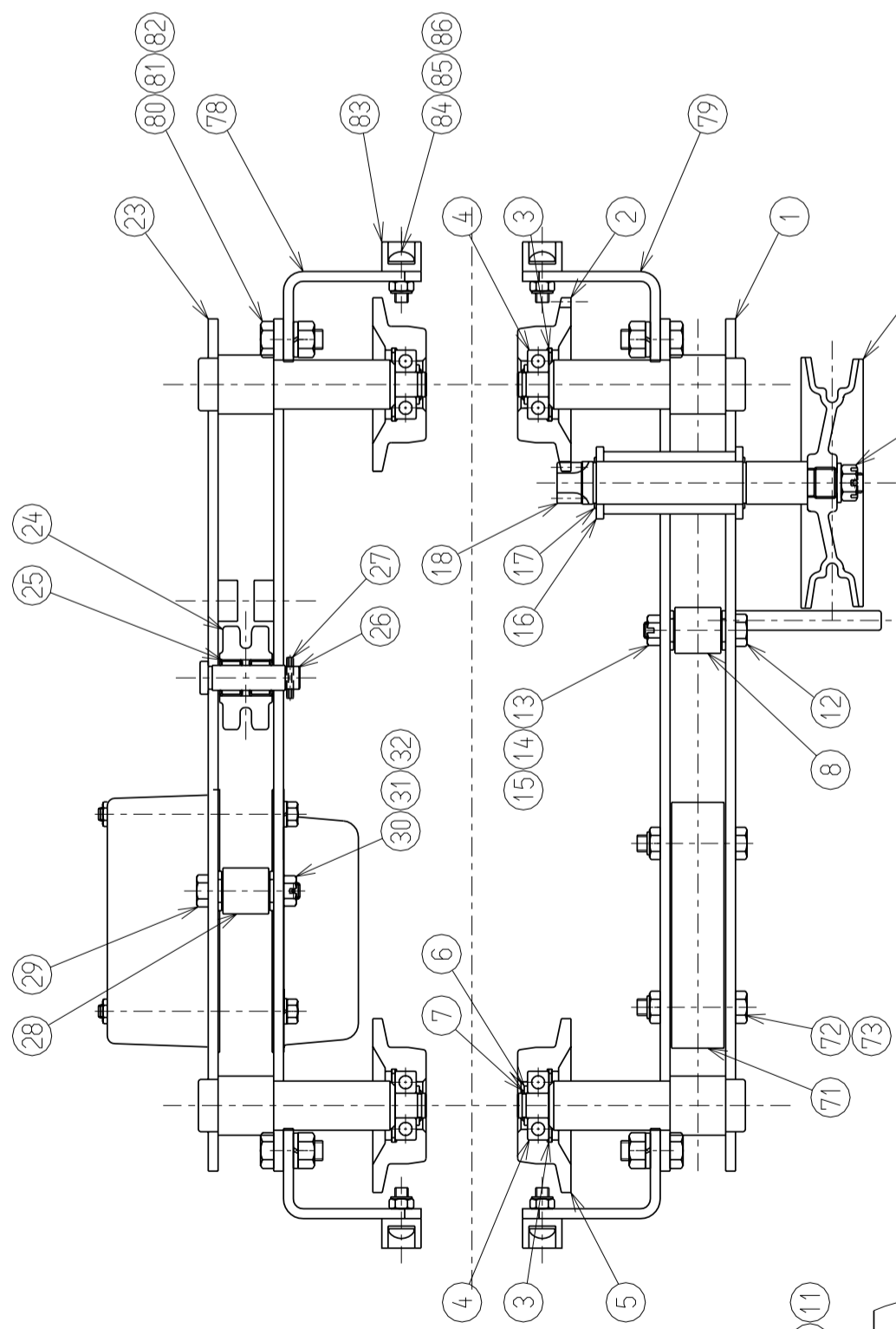

SHB100

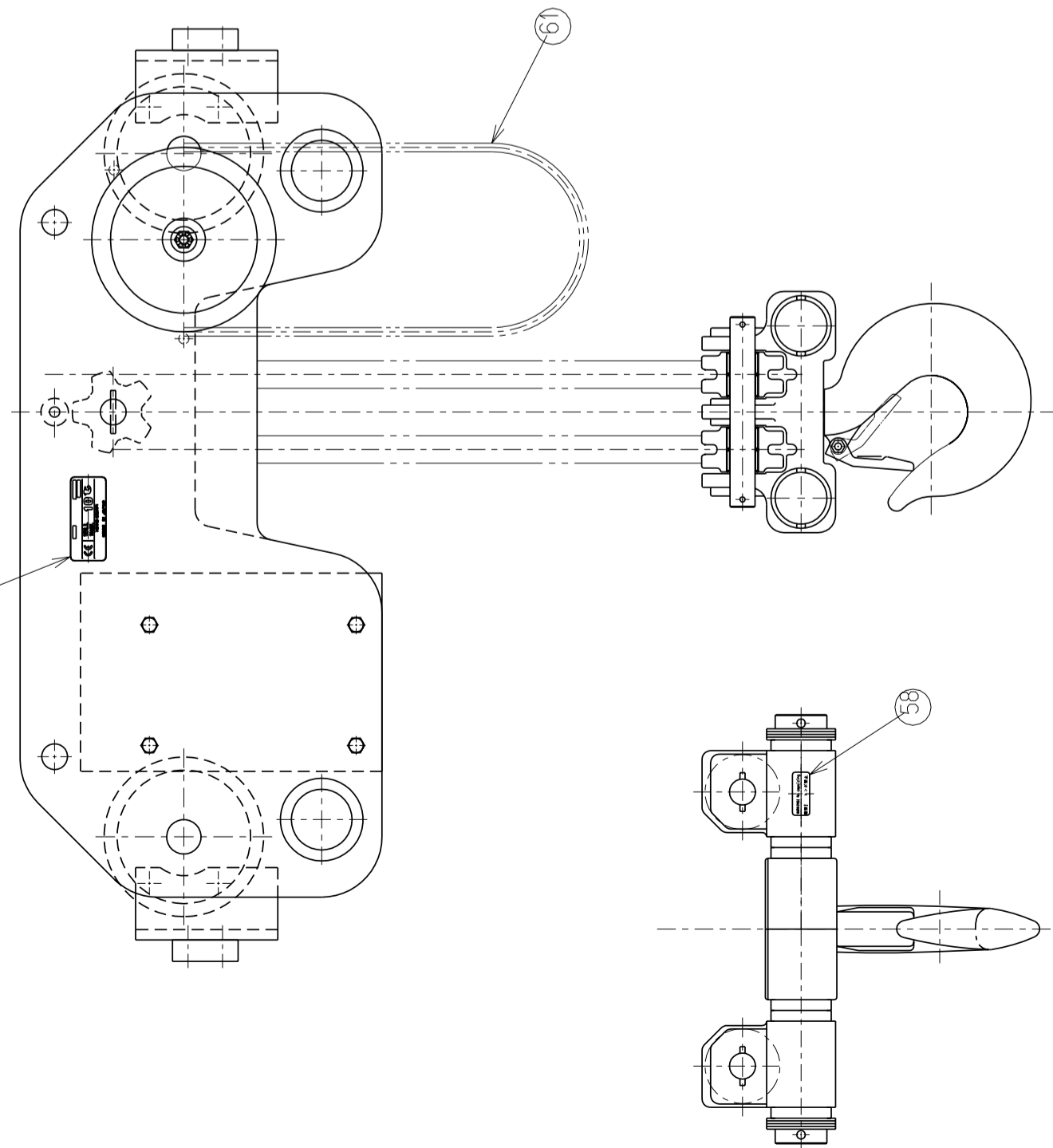
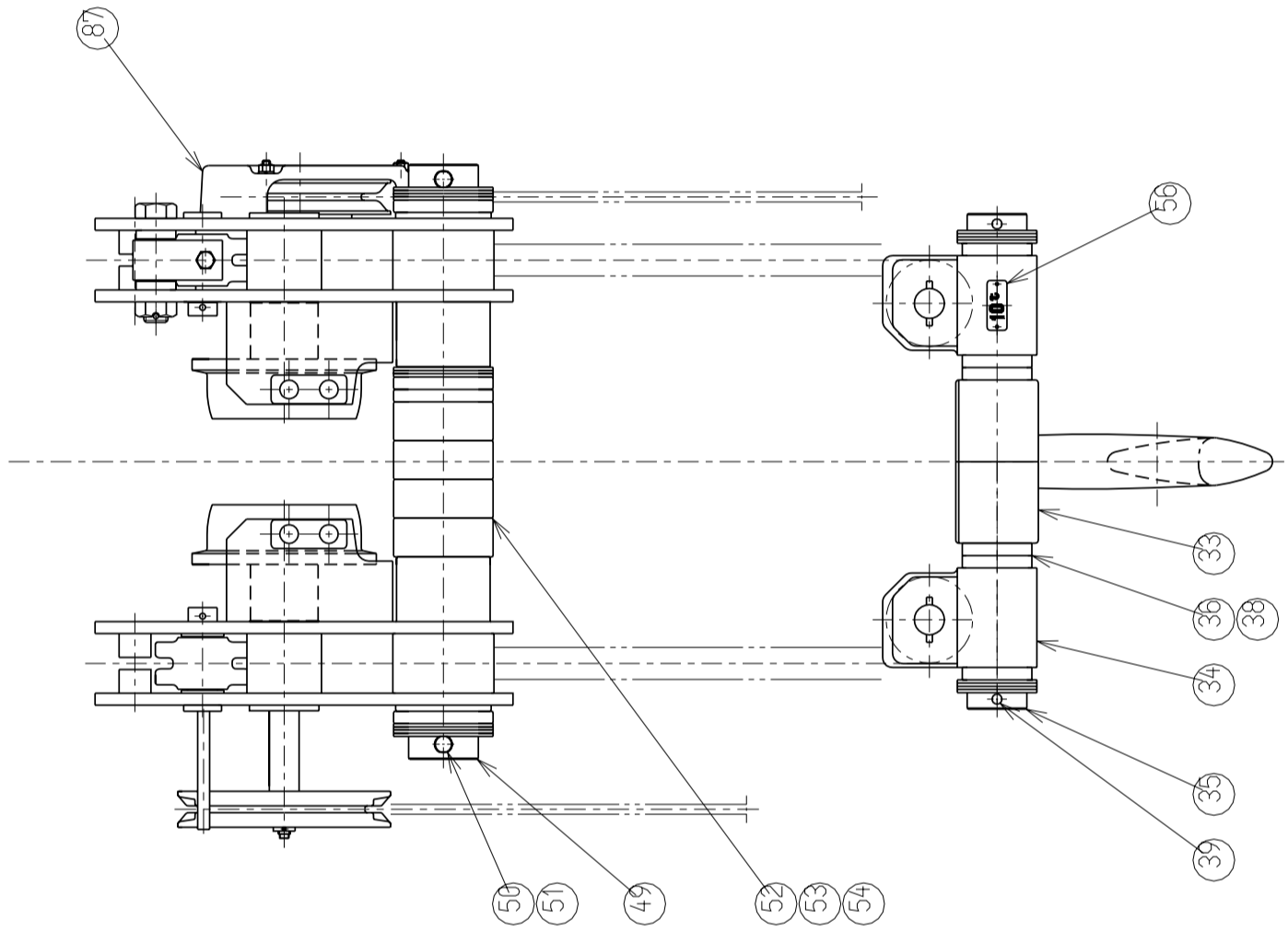
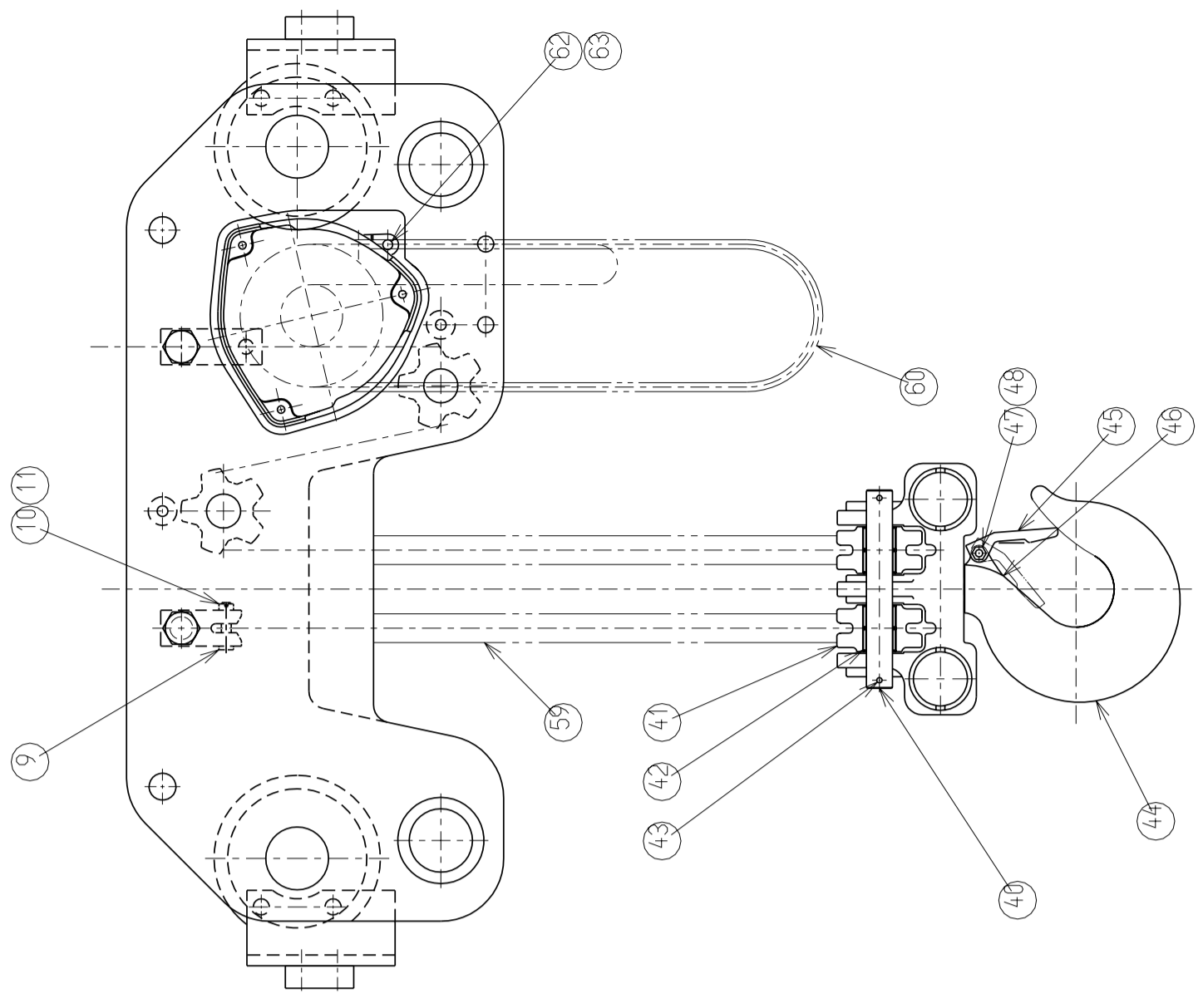
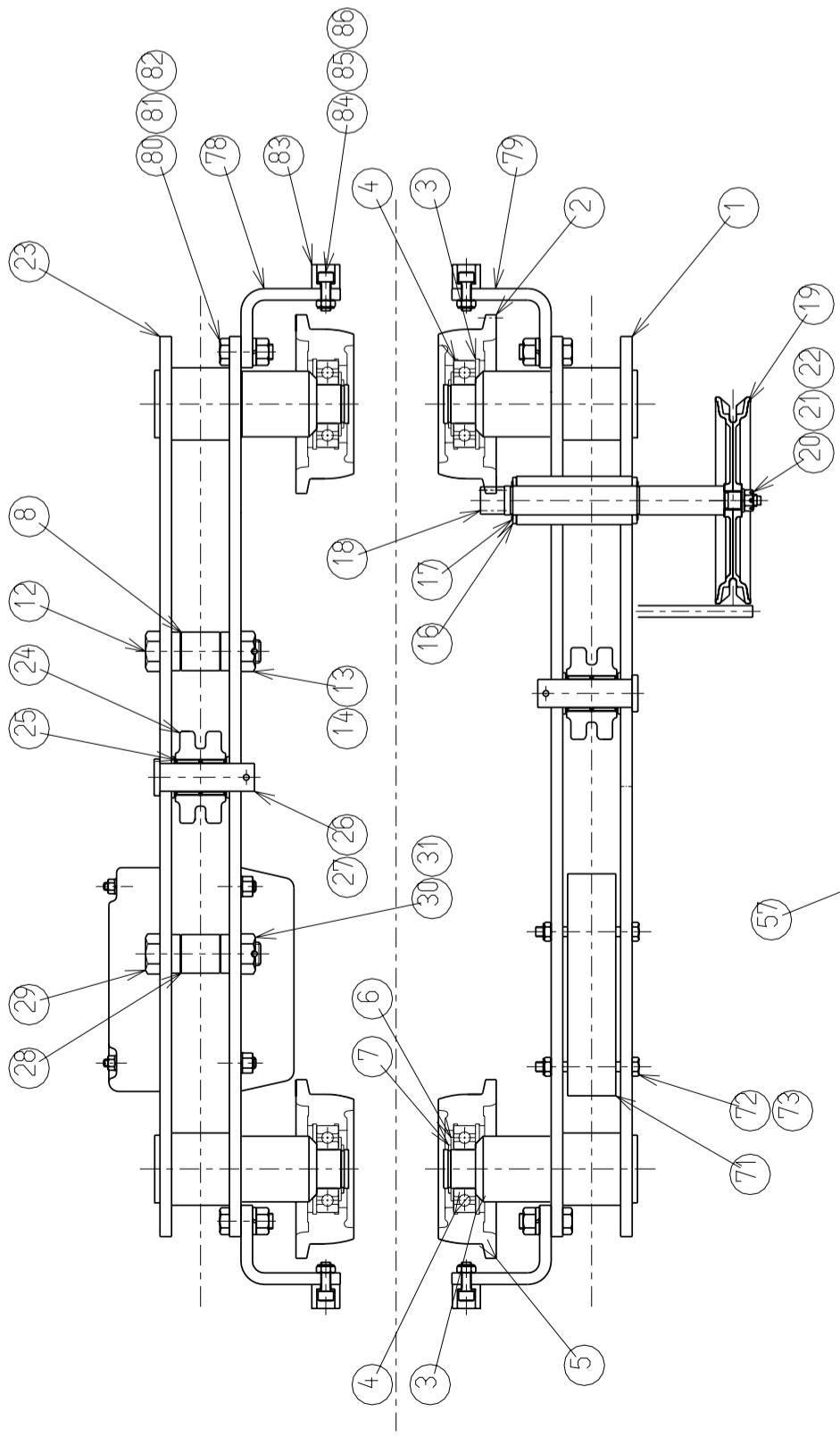

SHB100 with chain container

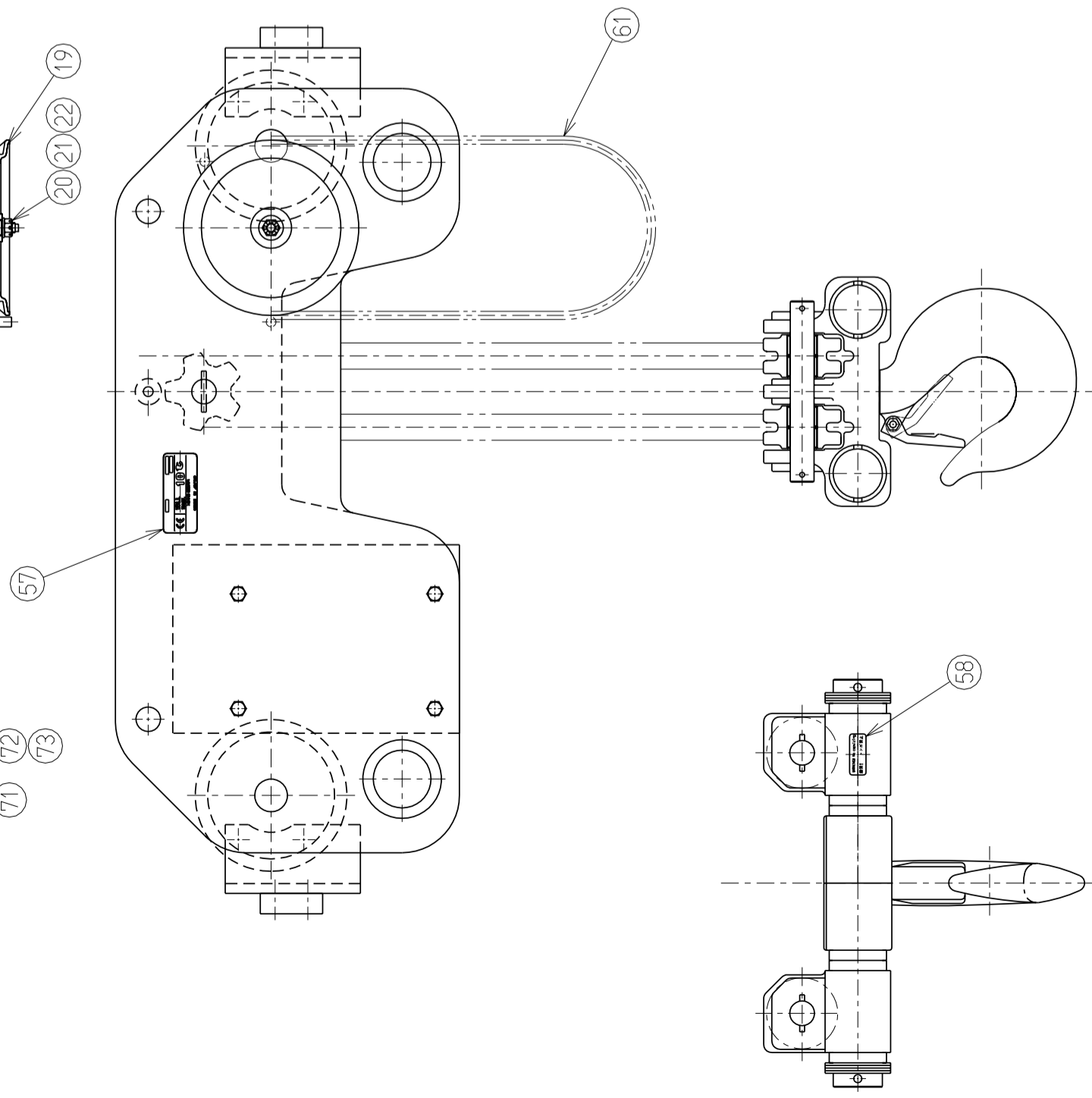
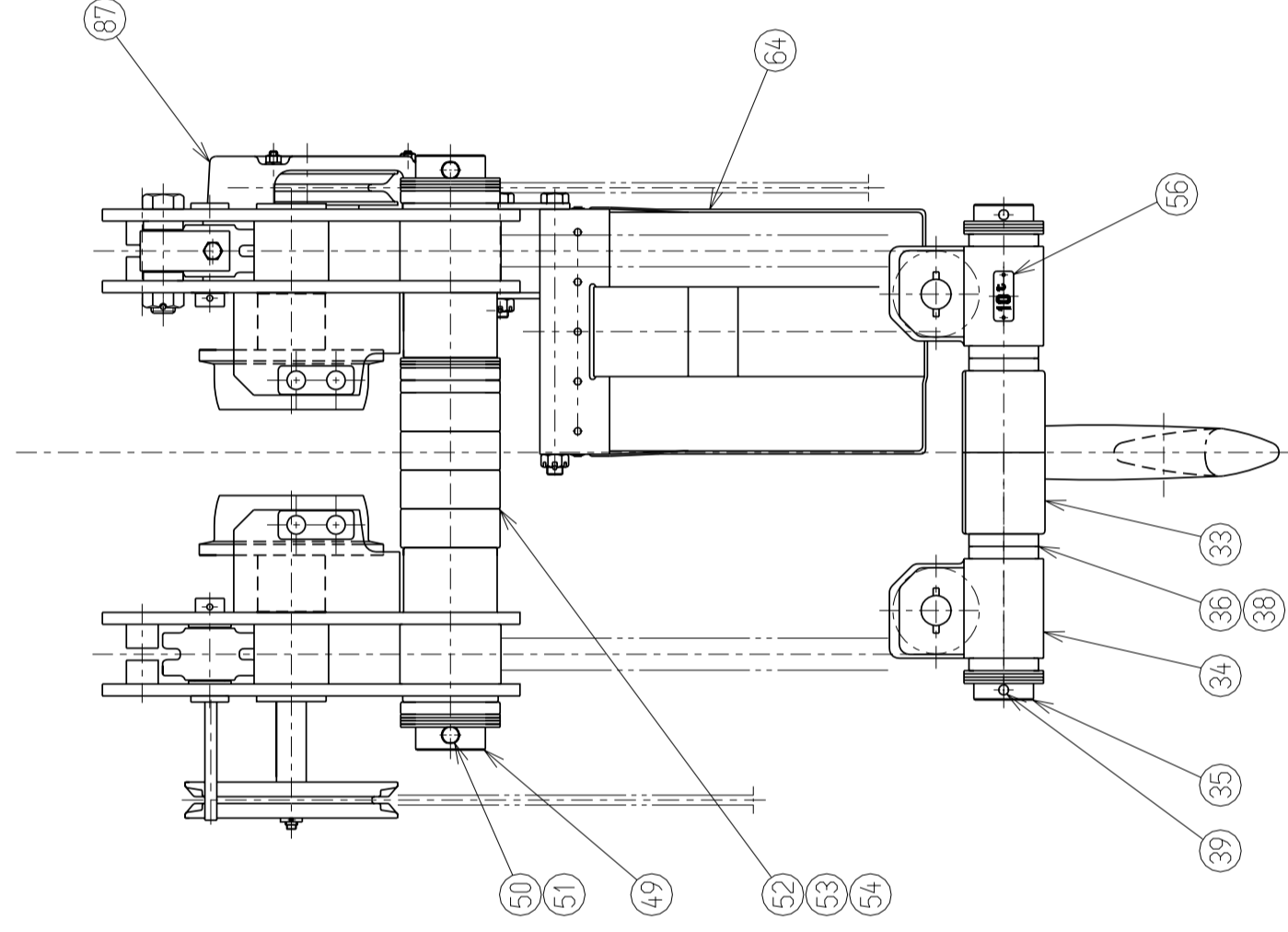
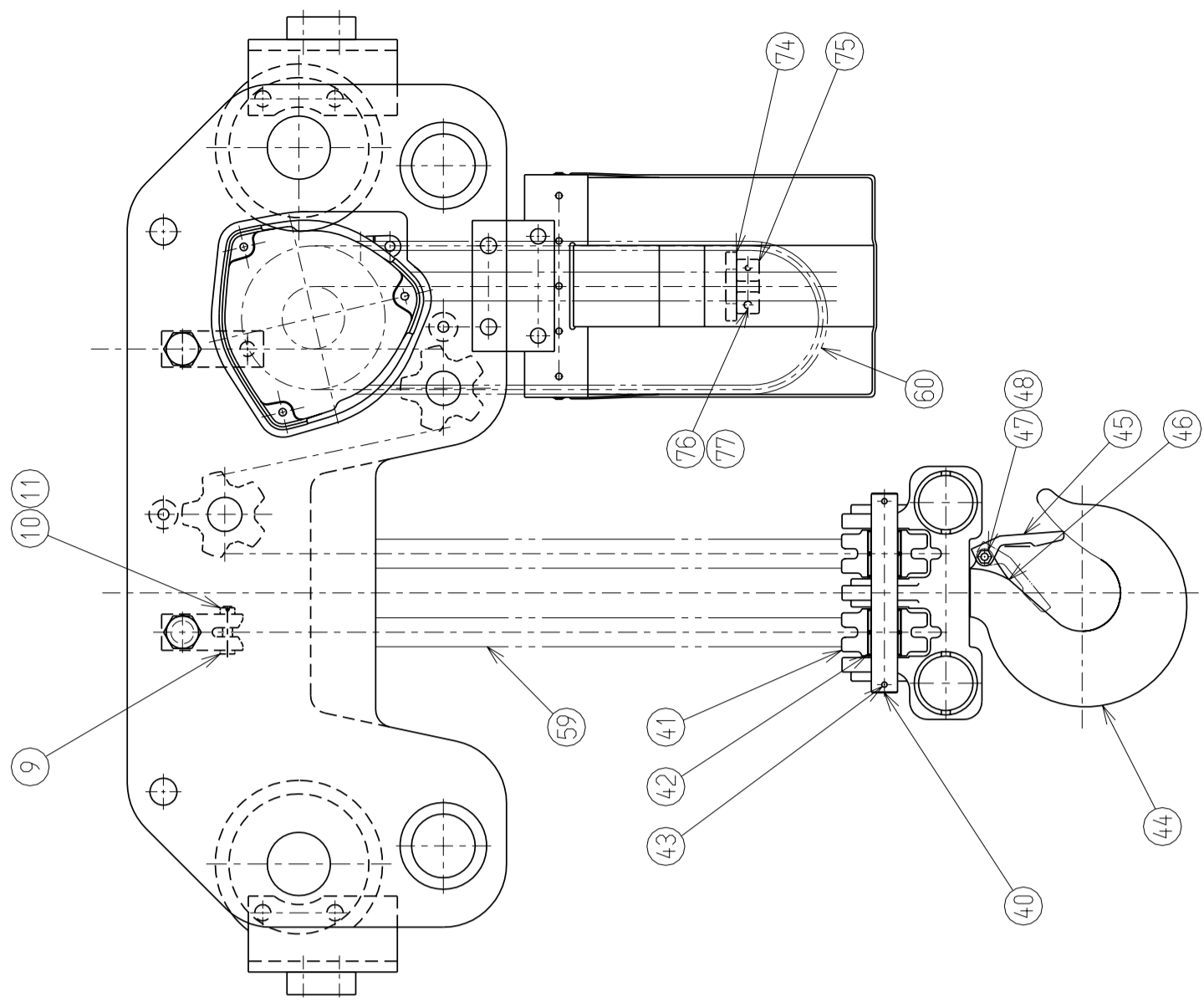
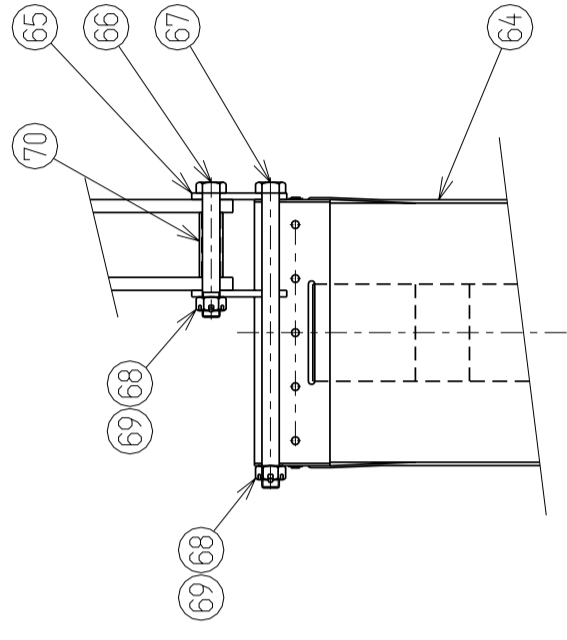
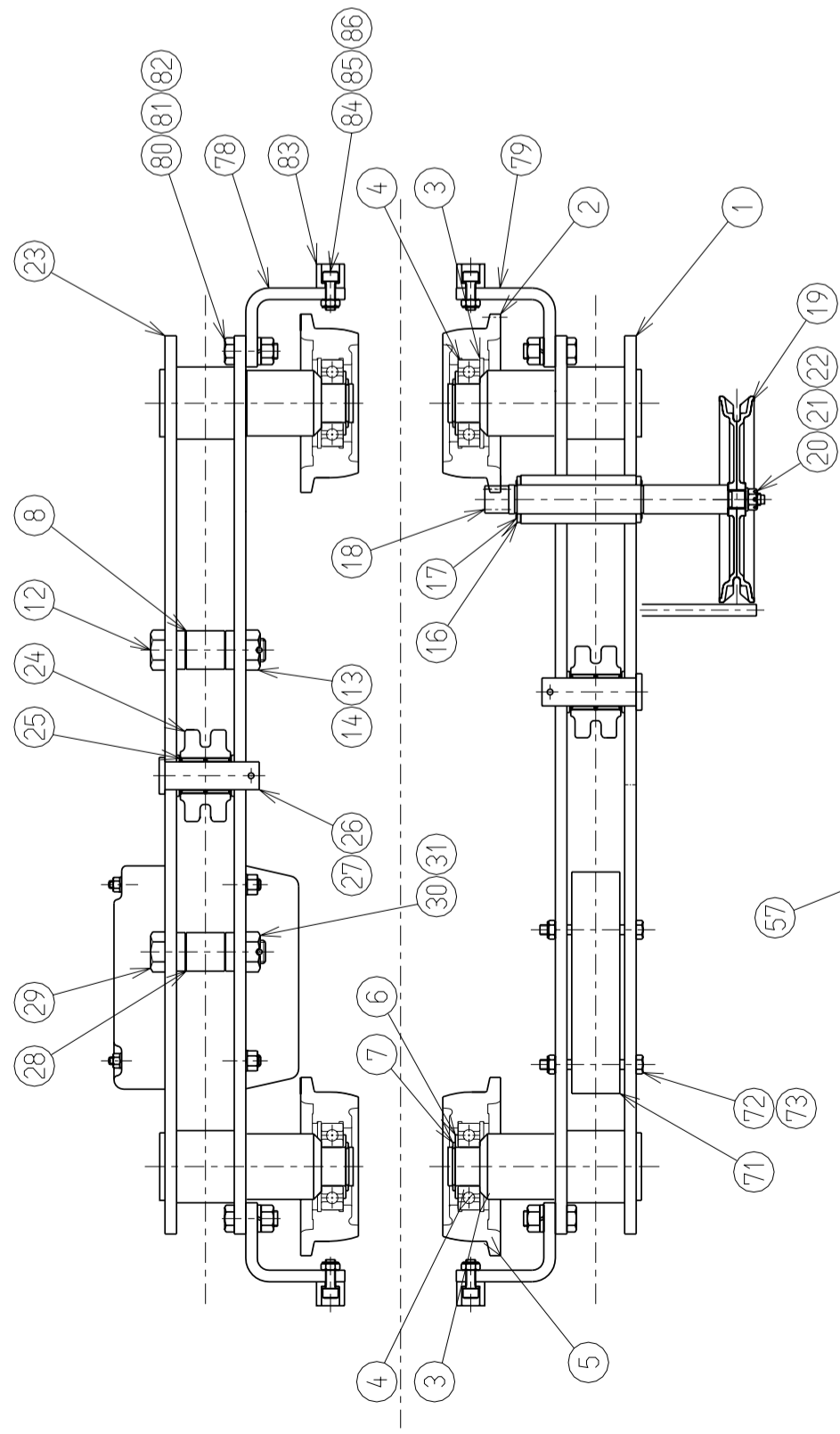

SHB010

Fig. No.	Part name	No. per hoist	Remarks
1	Side plate G assembly	1	
2	Track wheel G	1	
3	Snap ring	4	S-42
4	Ball bearing	4	6302ZZ
5	Track wheel S	3	
6	Track wheel washer	4	
7	Snap ring	4	S-15
8	Connection yoke C	1	
9	Chain pin	1	
10	Spring pin	1	ϕ 3x14
11	-	-	
12	Hexagon head bolt	1	
13	Slotted nut	1	L-M10
14	Split pin	1	ϕ 2.5x25
15	-	-	
16	Plain washer	2	M24
17	Snap ring	2	S-26
18	Pinion	1	
19	Hand wheel	1	
20	Slotted nut	1	L-M12
21	Plain washer	1	M12
22	Split pin	1	ϕ 3x22
23	Side plate S assembly	1	
24	Idle sheave	2	
25	Roller bearing	4	
26	Top Idle sheave shaft	2	
27	Spring pin	2	ϕ 4x25
28	Suspender C	1	
29	Hexagon head bolt	1	
30	Slotted nut	1	L-M10
31	Split pin	1	ϕ 2.5x25
32	-	-	
33	Suspender A	2	
34	Suspender B	2	
35	Lower shaft	2	
36	Spacer	6(10)	() in the case of width beam
37	Fixing spacer	0(2)	() in the case of width beam
38	Thin spacer	15(13)	() in the case of width beam
39	Spring pin	4	ϕ 6x45
40	Bottom Idle sheave shaft	2	
41	Idle sheave	2	
42	Roller bearing	4	
43	Spring pin	4	ϕ 4x25
44	Bottom hook	1	
45	Hook latch	1	
46	Hook latch spring	1	
47	Hook latch nut	1	
48	Hook latch bolt	1	
49	Upper shaft	2	
50	Shaft stopper pin	4	
51	Split pin	4	ϕ 4x20
52	Thick spacer	5(7)	() in the case of width beam
53	Fixing spacer	2(4)	() in the case of width beam

SHB010

Fig. No.	Part name	No. per hoist	Remarks
54	Thin spacer	5(11)	() in the case of width beam
55	Thin spacer C	4	
56	Name plate	1	
57	Name plate B	1	
58	Name plate C	1	
59	Load chain	1	
60	Hand chain	1	for Chain hoist
61	Hand chain	1	for Geared trolley
62	Stopper pin	1	
63	Split pin	1	ϕ 2x12
64	-	-	
65	-	-	
66	-	-	
67	-	-	
68	-	-	
69	-	-	
70	-	-	
71	Balancer	1	
72	Hexagon head bolt	4	M10x60x26
73	U nut	4	M10
74	-	-	
75	-	-	
76	-	-	
77	-	-	
78	Bumper L	2	
79	Bumper R	2	
80	Hexagon head bolt	8	M12x30x30
81	Spring washer	8	2-M12
82	Nut	8	1-M12
83	Buffer	4	
84	Cross recessed head screws	8	M8x25x25
85	Plain washer	8	M8 small
86	U nut	8	M8
87	Chain hoist	1	reference in a owner's manual for kito manual chain hoist

SHB020

Fig. No.	Part name	No. per hoist	Remarks
1	Side plate G assembly	1	
2	Track wheel G	1	
3	Snap ring	4	S-52
4	Ball bearing	4	6304ZZ
5	Track wheel S	3	
6	Track wheel washer	4	
7	Snap ring	4	S20
8	Connection yoke C	1	
9	Chain pin	1	
10	Spring pin	1	ϕ 4x20
11	-	-	
12	Hexagon head bolt	1	
13	Slotted nut	1	L-M16
14	Split pin	1	ϕ 4x32
15	-	-	
16	Plain washer	2	M24
17	Snap ring	2	S-26
18	Pinion	1	
19	Hand wheel	1	
20	Slotted nut	1	L-M12
21	Plain washer	1	M12
22	Split pin	1	ϕ 3x22
23	Side plate S assembly	1	
24	Idle sheave	2	
25	Roller bearing	4	
26	Top Idle sheave shaft	2	
27	Spring pin	2	ϕ 5x32
28	Suspender C	1	
29	Hexagon head bolt	1	
30	Slotted nut	1	L-M16
31	Split pin	1	ϕ 4x32
32	-	-	
33	Suspender A	2	
34	Suspender B	2	
35	Lower shaft	2	
36	Spacer	10(6)	() in the case of width beam
37	Fixing spacer	0(4)	() in the case of width beam
38	Thin spacer	12(12)	() in the case of width beam
39	Spring pin	4	ϕ 8x50
40	Bottom Idle sheave shaft	2	
41	Idle sheave	2	
42	Roller bearing	4	
43	Spring pin	4	ϕ 5x32
44	Bottom hook	1	
45	Hook latch	1	
46	Hook latch spring	1	
47	Hook latch nut	1	
48	Hook latch bolt	1	
49	Upper shaft	2	
50	Shaft stopper pin	4	
51	Split pin	4	ϕ 4x20
52	Thick spacer	4(6)	() in the case of width beam
53	Fixing spacer	4(6)	() in the case of width beam

SHB020

Fig. No.	Part name	No. per hoist	Remarks
54	Thin spacer	10(10)	() in the case of width beam
55	-	-	
56	Name plate	1	
57	Name plate B	1	
58	Name plate C	1	
59	Load chain	1	
60	Hand chain	1	for Chain hoist
61	Hand chain	1	for Geared trolley
62	Stopper pin	1	
63	Split pin	1	ϕ 2x15
64	-	-	
65	-	-	
66	-	-	
67	-	-	
68	-	-	
69	-	-	
70	-	-	
71	Balancer	1	
72	Hexagon head bolt	4	M10x75x26
73	U nut	4	M10
74	-	-	
75	-	-	
76	-	-	
77	-	-	
78	Bumper L	2	
79	Bumper R	2	
80	Hexagon head bolt	8	M12x35x20
81	Spring washer	8	2-M12
82	Nut	8	1-M12
83	Buffer	4	
84	Cross recessed head screws	8	M8x25x25
85	Plain washer	8	M8 small
86	U nut	8	M8
87	Chain hoist	1	reference in a owner's manual for kito manual chain hoist

SHB030

Fig. No.	Part name	No. per hoist	Remarks
1	Side plate G assembly	1	
2	Track wheel G	1	
3	Snap ring	4	S-62
4	Ball bearing	4	63025Z
5	Track wheel S	3	
6	Track wheel washer	4	
7	Snap ring	4	S-20
8	Connection yoke C	1	
9	Chain pin	1	
10	Spring pin	1	ϕ 4x25
11	-	-	
12	Hexagon head bolt	1	
13	Slotted nut	1	L-M18
14	Split pin	1	ϕ 4x40
15	-	-	
16	Plain washer	2	M24
17	Snap ring	2	S-26
18	Pinion	1	
19	Hand wheel	1	
20	Slotted nut	1	L-M12
21	Plain washer	1	M12
22	Split pin	1	ϕ 3x22
23	Side plate S assembly	1	
24	Idle sheave	2	
25	Roller bearing	4	
26	Top Idle sheave shaft	2	
27	Spring pin	2	ϕ 6x36
28	Suspender C	1	
29	Hexagon head bolt	1	
30	Slotted nut	1	L-M18
31	Split pin	1	ϕ 4x40
32	-	-	
33	Suspender A	2	
34	Suspender B	2	
35	Lower shaft	2	
36	Spacer	8(4)	() in the case of width beam
37	Fixing spacer	0(4)	() in the case of width beam
38	Thin spacer	12(12)	() in the case of width beam
39	Spring pin	4	ϕ 10x63
40	Bottom Idle sheave shaft	2	
41	Idle sheave	2	
42	Roller bearing	4	
43	Spring pin	4	ϕ 6x36
44	Bottom hook	1	
45	Hook latch	1	
46	Hook latch spring	1	
47	Hook latch nut	1	
48	Hook latch bolt	1	
49	Upper shaft	2	
50	Shaft stopper pin	4	
51	Split pin	4	ϕ 4x22
52	Thick spacer	4(6)	() in the case of width beam
53	Fixing spacer	4(6)	() in the case of width beam

SHB030

Fig. No.	Part name	No. per hoist	Remarks
54	Thin spacer	11(11)	() in the case of width beam
55	-	-	
56	Name plate	1	
57	Name plate B	1	
58	Name plate C	1	
59	Load chain	1	
60	Hand chain	1	for Chain hoist
61	Hand chain	1	for Geared trolley
62	Stopper pin	1	
63	Split pin	1	ϕ 2.5x15
64	-	-	
65	-	-	
66	-	-	
67	-	-	
68	-	-	
69	-	-	
70	-	-	
71	Balancer	1	
72	Hexagon head bolt	4	M10x85x26
73	U nut	4	M10
74	-	-	
75	-	-	
76	-	-	
77	-	-	
78	Bumper L	2	
79	Bumper R	2	
80	Hexagon head bolt	8	M12x35x20
81	Spring washer	8	2-M12
82	Nut	8	1-M12
83	Buffer	4	
84	Cross recessed head screws	8	M8x25x25
85	Plain washer	8	M8 small
86	U nut	8	M8
87	Chain hoist	1	reference in a owner's manual for kito manual chain hoist

SHB010 with chain container

Fig. No.	Part name	No. per hoist	Remarks
1	Side plate G assembly	1	
2	Track wheel G	1	
3	Snap ring	4	S-42
4	Ball bearing	4	6302ZZ
5	Track wheel S	3	
6	Track wheel washer	4	
7	Snap ring	4	S-15
8	Connection yoke C	1	
9	Chain pin	1	
10	Spring pin	1	ϕ 3x14
11	-	-	
12	Hexagon head bolt	1	
13	Slotted nut	1	L-M10
14	Split pin	1	ϕ 2.5x25
15	-	-	
16	Plain washer	2	M24
17	Snap ring	2	S-26
18	Pinion	1	
19	Hand wheel	1	
20	Slotted nut	1	L-M12
21	Plain washer	1	M12
22	Split pin	1	ϕ 3x22
23	Side plate S assembly	1	
24	Idle sheave	2	
25	Roller bearing	4	
26	Top Idle sheave shaft	2	
27	Spring pin	2	ϕ 4x25
28	Suspender C	1	
29	Hexagon head bolt	1	
30	Slotted nut	1	L-M10
31	Split pin	1	ϕ 2.5x25
32	-	-	
33	Suspender A	2	
34	Suspender B	2	
35	Lower shaft	2	
36	Spacer	6(10)	() in the case of width beam
37	Fixing spacer	0(2)	() in the case of width beam
38	Thin spacer	15(13)	() in the case of width beam
39	Spring pin	4	ϕ 6x45
40	Bottom Idle sheave shaft	2	
41	Idle sheave	2	
42	Roller bearing	4	
43	Spring pin	4	ϕ 4x25
44	Bottom hook	1	
45	Hook latch	1	
46	Hook latch spring	1	
47	Hook latch nut	1	
48	Hook latch bolt	1	
49	Upper shaft	2	
50	Shaft stopper pin	4	
51	Split pin	4	ϕ 4x20
52	Thick spacer	5(7)	() in the case of width beam
53	Fixing spacer	2(4)	() in the case of width beam

SHB010 with chain container

Fig. No.	Part name	No. per hoist	Remarks
54	Thin spacer	5(11)	() in the case of width beam
55	Thin spacer C	4	
56	Name plate	1	
57	Name plate B	1	
58	Name plate C	1	
59	Load chain	1	
60	Hand chain	1	for Chain hoist
61	Hand chain	1	for Geared trolley
62	-	-	
63	-	-	
64	Chain container assembly	1	
65	Container sling fitting	2	
66	Container sling fitting bolt A	2	
67	Container sling fitting bolt B	2	
68	Slotted nut	4	L-M12
69	Split pin	4	ϕ 3.2x25
70	Collar	2	
71	Balancer	1	
72	Hexagon head bolt	4	M10x60x26
73	U nut	4	M10
74	Stopper collar	1	
75	Stopper	2	
76	Socket bolt	2	M6x16x16
77	Spring washer	2	2-M6
78	Bumper L	2	
79	Bumper R	2	
80	Hexagon head bolt	8	M12x30x30
81	Spring washer	8	2-M12
82	Nut	8	1-M12
83	Buffer	4	
84	Cross recessed head screws	8	M8x25x25
85	Plain washer	8	M8 small
86	U nut	8	M8
87	Chain hoist	1	reference in a owner's manual for kito manual chain hoist

SHB020 with chain container

Fig. No.	Part name	No. per hoist	Remarks
1	Side plate G assembly	1	
2	Track wheel G	1	
3	Snap ring	4	S-52
4	Ball bearing	4	6304ZZ
5	Track wheel S	3	
6	Track wheel washer	4	
7	Snap ring	4	S20
8	Connection yoke C	1	
9	Chain pin	1	
10	Spring pin	1	ϕ 4x20
11	-	-	
12	Hexagon head bolt	1	
13	Slotted nut	1	L-M16
14	Split pin	1	ϕ 4x32
15	-	-	
16	Plain washer	2	M24
17	Snap ring	2	S-26
18	Pinion	1	
19	Hand wheel	1	
20	Slotted nut	1	L-M12
21	Plain washer	1	M12
22	Split pin	1	ϕ 3x22
23	Side plate S assembly	1	
24	Idle sheave	2	
25	Roller bearing	4	
26	Top Idle sheave shaft	2	
27	Spring pin	2	ϕ 5x32
28	Suspender C	1	
29	Hexagon head bolt	1	
30	Slotted nut	1	L-M16
31	Split pin	1	ϕ 4x32
32	-	-	
33	Suspender A	2	
34	Suspender B	2	
35	Lower shaft	2	
36	Spacer	6(10)	() in the case of width beam
37	Fixing spacer	0(2)	() in the case of width beam
38	Thin spacer	15(13)	() in the case of width beam
39	Spring pin	4	ϕ 8x50
40	Bottom Idle sheave shaft	2	
41	Idle sheave	2	
42	Roller bearing	4	
43	Spring pin	4	ϕ 5x32
44	Bottom hook	1	
45	Hook latch	1	
46	Hook latch spring	1	
47	Hook latch nut	1	
48	Hook latch bolt	1	
49	Upper shaft	2	
50	Shaft stopper pin	4	
51	Split pin	4	ϕ 4x20
52	Thick spacer	4(6)	() in the case of width beam
53	Fixing spacer	4(6)	() in the case of width beam

SHB020 with chain container

Fig. No.	Part name	No. per hoist	Remarks
54	Thin spacer	10(10)	() in the case of width beam
55	-	-	
56	Name plate	1	
57	Name plate B	1	
58	Name plate C	1	
59	Load chain	1	
60	Hand chain	1	for Chain hoist
61	Hand chain	1	for Geared trolley
62	-	-	
63	-	-	
64	Chain container assembly	1	
65	Container sling fitting	2	
66	Container sling fitting bolt A	2	
67	Container sling fitting bolt B	2	
68	Slotted nut	4	L-M12
69	Split pin	4	ϕ 3.2x25
70	Collar	2	
71	Balancer	1	
72	Hexagon head bolt	4	M10x75x26
73	U nut	4	M10
74	Stopper collar	1	
75	Stopper	2	
76	Socket bolt	2	M6x25x25
77	Spring washer	2	2-M6
78	Bumper L	2	
79	Bumper R	2	
80	Hexagon head bolt	8	M12x35x20
81	Spring washer	8	2-M12
82	Nut	8	1-M12
83	Buffer	4	
84	Cross recessed head screws	8	M8x25x25
85	Plain washer	8	M8 small
86	U nut	8	M8
87	Chain hoist	1	reference in a owner's manual for kito manual chain hoist

SHB030 with chain container

Fig. No.	Part name	No. per hoist	Remarks
1	Side plate G assembly	1	
2	Track wheel G	1	
3	Snap ring	4	S-62
4	Ball bearing	4	63025Z
5	Track wheel S	3	
6	Track wheel washer	4	
7	Snap ring	4	S-20
8	Connection yoke C	1	
9	Chain pin	1	
10	Spring pin	1	φ 4x25
11	-	-	
12	Hexagon head bolt	1	
13	Slotted nut	1	L-M18
14	Split pin	1	φ 4x40
15	-	-	
16	Plain washer	2	M24
17	Snap ring	2	S-26
18	Pinion	1	
19	Hand wheel	1	
20	Slotted nut	1	L-M12
21	Plain washer	1	M12
22	Split pin	1	φ 3x22
23	Side plate S assembly	1	
24	Idle sheave	2	
25	Roller bearing	4	
26	Top Idle sheave shaft	2	
27	Spring pin	2	φ 6x36
28	Suspender C	1	
29	Hexagon head bolt	1	
30	Slotted nut	1	L-M18
31	Split pin	1	φ 4x40
32	-	-	
33	Suspender A	2	
34	Suspender B	2	
35	Lower shaft	2	
36	Spacer	6(10)	() in the case of width beam
37	Fixing spacer	0(2)	() in the case of width beam
38	Thin spacer	15(13)	() in the case of width beam
39	Spring pin	4	φ 10x63
40	Bottom Idle sheave shaft	2	
41	Idle sheave	2	
42	Roller bearing	4	
43	Spring pin	4	φ 6x36
44	Bottom hook	1	
45	Hook latch	1	
46	Hook latch spring	1	
47	Hook latch nut	1	
48	Hook latch bolt	1	
49	Upper shaft	2	
50	Shaft stopper pin	4	
51	Split pin	4	φ 4x22
52	Thick spacer	4(6)	() in the case of width beam
53	Fixing spacer	4(6)	() in the case of width beam

SHB030 with chain container

Fig. No.	Part name	No. per hoist	Remarks
54	Thin spacer	11(11)	() in the case of width beam
55	-	-	
56	Name plate	1	
57	Name plate B	1	
58	Name plate C	1	
59	Load chain	1	
60	Hand chain	1	for Chain hoist
61	Hand chain	1	for Geared trolley
62	-	-	
63	-	-	
64	Chain container assembly	1	
65	Container sling fitting	2	
66	Container sling fitting bolt A	2	
67	Container sling fitting bolt B	2	
68	Slotted nut	4	L-M12
69	Split pin	4	φ 3.2x25
70	Collar	2	
71	Balancer	1	
72	Hexagon head bolt	4	M10x85x26
73	U nut	4	M10
74	Stopper collar	1	
75	Stopper	2	
76	Socket bolt	2	M6x25x25
77	Spring washer	2	2-M6
78	Bumper L	2	
79	Bumper R	2	
80	Hexagon head bolt	8	M12x35x20
81	Spring washer	8	2-M12
82	Nut	8	1-M12
83	Buffer	4	
84	Cross recessed head screws	8	M8x25x25
85	Plain washer	8	M8 small
86	U nut	8	M8
87	Chain hoist	1	reference in a owner's manual for kito manual chain hoist

SHB050

Fig. No.	Part name	No. per hoist	Remarks
1	Side plate G assembly	1	
2	Track wheel G	1	
3	Snap ring	4	S-80
4	Ball bearing	4	6307ZZ
5	Track wheel S	3	
6	Track wheel washer	4	
7	Snap ring	4	S-35
8	Connection yoke C	1	
9	Chain pin	1	
10	Slotted nut	1	L-M10
11	Split pin	1	ϕ 2x14
12	Hexagon head bolt	1	
13	Slotted nut	1	L-M24
14	Split pin	1	ϕ 5x45
15	Plain washer	1	M24
16	Plain washer	2	M24
17	Snap ring	2	S-26
18	Pinion	1	
19	Hand wheel	1	
20	Slotted nut	1	L-M12
21	Plain washer	1	M12
22	Split pin	1	ϕ 3x22
23	Side plate S assembly	1	
24	Idle sheave	2	
25	Roller bearing	4	
26	Top Idle sheave shaft	2	
27	Spring pin	2	ϕ 6x45
28	Suspender C	1	
29	Hexagon head bolt	1	
30	Slotted nut	1	L-M24
31	Split pin	1	ϕ 5x45
32	Plain washer	1	M24
33	Suspender A	2	
34	Suspender B	2	
35	Lower shaft	2	
36	Spacer	4(12)	() in the case of width beam
37	Fixing spacer	0(0)	() in the case of width beam
38	Thin spacer	11(11)	() in the case of width beam
39	Spring pin	4	ϕ 10x70
40	Bottom Idle sheave shaft	2	
41	Idle sheave	2	
42	Roller bearing	4	
43	Spring pin	4	ϕ 6x50
44	Bottom hook	1	
45	Hook latch	1	
46	Hook latch spring	1	
47	Hook latch nut	1	
48	Hook latch bolt	1	
49	Upper shaft	2	
50	Shaft stopper pin	4	
51	Split pin	4	ϕ 4x22
52	Thick spacer	17(25)	() in the case of width beam
53	Fixing spacer	0(0)	() in the case of width beam

SHB050

Fig. No.	Part name	No. per hoist	Remarks
54	Thin spacer	9(9)	() in the case of width beam
55	-	-	
56	Name plate	1	
57	Name plate B	1	
58	Name plate C	1	
59	Load chain	1	
60	Hand chain	1	for Chain hoist
61	Hand chain	1	for Geared trolley
62	Stopper pin	1	
63	Split pin	1	φ 2.5x18
64	-	-	
65	-	-	
66	-	-	
67	-	-	
68	-	-	
69	-	-	
70	-	-	
71	Balancer	1	
72	Hexagon head bolt	4	M10x100x26
73	U nut	4	M10
74	-	-	
75	-	-	
76	-	-	
77	-	-	
78	Bumper L	2	
79	Bumper R	2	
80	Hexagon head bolt	8	M16x40x40
81	Spring washer	8	2-M16
82	Nut	8	1-M16
83	Buffer	4	
84	Hexagon socket head cap screw	8	M10x30x30
85	Plain washer	8	M10 small
86	U nut	8	M10
87	Chain hoist	1	reference in a owner's manual for kito manual chain hoist

SHB050 with chain container

Fig. No.	Part name	No. per hoist	Remarks
1	Side plate G assembly	1	
2	Track wheel G	1	
3	Snap ring	4	S-42
4	Ball bearing	4	6302ZZ
5	Track wheel S	3	
6	Track wheel washer	4	
7	Snap ring	4	S-35
8	Connection yoke C	1	
9	Chain pin	1	
10	Slotted nut	1	L-M10
11	Split pin	1	φ 2x14
12	Hexagon head bolt	1	
13	Slotted nut	1	L-M24
14	Split pin	1	φ 5x45
15	Plain washer	1	M24
16	Plain washer	2	M24
17	Snap ring	2	S-26
18	Pinion	1	
19	Hand wheel	1	
20	Slotted nut	1	L-M12
21	Plain washer	1	M12
22	Split pin	1	φ 3x22
23	Side plate S assembly	1	
24	Idle sheave	2	
25	Roller bearing	4	
26	Top Idle sheave shaft	2	
27	Spring pin	2	φ 6x45
28	Suspender C	1	
29	Hexagon head bolt	1	
30	Slotted nut	1	L-M24
31	Split pin	1	φ 5x45
32	Plain washer	1	M24
33	Suspender A	2	
34	Suspender B	2	
35	Lower shaft	2	
36	Spacer	4(12)	() in the case of width beam
37	Fixing spacer	0(0)	() in the case of width beam
38	Thin spacer	11(11)	() in the case of width beam
39	Spring pin	4	φ 10x70
40	Bottom Idle sheave shaft	2	
41	Idle sheave	2	
42	Roller bearing	4	
43	Spring pin	4	φ 6x50
44	Bottom hook	1	
45	Hook latch	1	
46	Hook latch spring	1	
47	Hook latch nut	1	
48	Hook latch bolt	1	
49	Upper shaft	2	
50	Shaft stopper pin	4	
51	Split pin	4	φ 4x22
52	Thick spacer	17(25)	() in the case of width beam
53	Fixing spacer	0(0)	() in the case of width beam

SHB050 with chain container

Fig. No.	Part name	No. per hoist	Remarks
54	Thin spacer	9(9)	() in the case of width beam
55	-	-	
56	Name plate	1	
57	Name plate B	1	
58	Name plate C	1	
59	Load chain	1	
60	Hand chain	1	for Chain hoist
61	Hand chain	1	for Geared trolley
62	-	-	
63	-	-	
64	Chain container assembly	1	
65	Container sling fitting	2	
66	Container sling fitting bolt A	2	
67	Container sling fitting bolt B	2	
68	Slotted nut	4	L-M16
69	Split pin	4	ϕ 4x32
70	Collar	2	
71	Balancer	1	
72	Hexagon head bolt	4	M10x100x26
73	U nut	4	M10
74	Stopper collar	1	
75	Stopper	2	
76	Socket bolt	2	M8x25x25
77	Spring washer	2	2-M8
78	Bumper L	2	
79	Bumper R	2	
80	Hexagon head bolt	8	M16x40x40
81	Spring washer	8	2-M16
82	Nut	8	1-M16
83	Buffer	4	
84	Hexagon socket head cap screw	8	M10x30x30
85	Plain washer	8	M10 small
86	U nut	8	M10
87	Chain hoist	1	reference in a owner's manual for kito manual chain hoist

SHB100 with chain container

Fig. No.	Part name	No. per hoist	Remarks
1	Side plate G assembly	1	
2	Track wheel G	1	
3	Snap ring	4	S-90
4	Ball bearing	4	6308ZZ
5	Track wheel S	3	
6	Track wheel washer	4	
7	Snap ring	4	S-40
8	Connection yoke C	1	
9	Chain pin	1	
10	Slotted nut	1	L-M10
11	Split pin	1	ϕ 2x14
12	Hexagon head bolt	1	
13	Slotted nut	1	L-M24
14	Split pin	1	ϕ 5x45
15	-	-	
16	Plain washer	2	M24
17	Snap ring	2	S-26
18	Pinion	1	
19	Hand wheel	1	
20	Slotted nut	1	L-M12
21	Plain washer	1	M12
22	Split pin	1	ϕ 3x22
23	Side plate S assembly	1	
24	Idle sheave	2	
25	Roller bearing	4	
26	Top Idle sheave shaft	2	
27	Spring pin	2	ϕ 6x45
28	Suspender C	1	
29	Hexagon head bolt	1	
30	Slotted nut	1	L-M24
31	Split pin	1	ϕ 5x45
32	-	-	
33	Suspender A	2	
34	Suspender B	2	
35	Lower shaft	2	
36	Spacer	4(12)	() in the case of width beam
37	Fixing spacer	0(0)	() in the case of width beam
38	Thin spacer	16(11)	() in the case of width beam
39	Spring pin	4	ϕ 10x80
40	Bottom Idle sheave shaft	2	
41	Idle sheave	2	
42	Roller bearing	4	
43	Spring pin	4	ϕ 6x50
44	Bottom hook	1	
45	Hook latch	1	
46	Hook latch spring	1	
47	Hook latch nut	1	
48	Hook latch bolt	1	
49	Upper shaft	2	
50	Shaft stopper pin	4	
51	Split pin	4	ϕ 4x28
52	Thick spacer	7(5)	() in the case of width beam
53	Fixing spacer	3(6)	() in the case of width beam

SHB100 with chain container

Fig. No.	Part name	No. per hoist	Remarks
54	Thin spacer	11(9)	() in the case of width beam
55	-	-	
56	Name plate	1	
57	Name plate B	1	
58	Name plate C	1	
59	Load chain	1	
60	Hand chain	1	for Chain hoist
61	Hand chain	1	for Geared trolley
62	Stopper pin	1	
63	Split pin	1	ϕ 2.5x18
64	-	-	
65	-	-	
66	-	-	
67	-	-	
68	-	-	
69	-	-	
70	-	-	
71	Balancer	1	
72	Hexagon head bolt	4	M10x100x26
73	U nut	4	M10
74	-	-	
75	-	-	
76	-	-	
77	-	-	
78	Bumper L	2	
79	Bumper R	2	
80	Hexagon head bolt	8	M16x45x45
81	Spring washer	8	2-M16
82	Nut	8	1-M16
83	Buffer	4	
84	Hexagon socket head cap screw	8	M10x30x30
85	Plain washer	8	M10 small
86	U nut	8	M10
87	Chain hoist	1	reference in a owner's manual for kito manual chain hoist

SHB100 with chain container

Fig. No.	Part name	No. per hoist	Remarks
1	Side plate G assembly	1	
2	Track wheel G	1	
3	Snap ring	4	S-90
4	Ball bearing	4	6308ZZ
5	Track wheel S	3	
6	Track wheel washer	4	
7	Snap ring	4	S-40
8	Connection yoke C	1	
9	Chain pin	1	
10	Slotted nut	1	L-M10
11	Split pin	1	ϕ 2x14
12	Hexagon head bolt	1	
13	Slotted nut	1	L-M24
14	Split pin	1	ϕ 5x45
15	-	-	
16	Plain washer	2	M24
17	Snap ring	2	S-26
18	Pinion	1	
19	Hand wheel	1	
20	Slotted nut	1	L-M12
21	Plain washer	1	M12
22	Split pin	1	ϕ 3x22
23	Side plate S assembly	1	
24	Idle sheave	2	
25	Roller bearing	4	
26	Top Idle sheave shaft	2	
27	Spring pin	2	ϕ 6x45
28	Suspender C	1	
29	Hexagon head bolt	1	
30	Slotted nut	1	L-M24
31	Split pin	1	ϕ 5x45
32	-	-	
33	Suspender A	2	
34	Suspender B	2	
35	Lower shaft	2	
36	Spacer	4(12)	() in the case of width beam
37	Fixing spacer	0(0)	() in the case of width beam
38	Thin spacer	16(11)	() in the case of width beam
39	Spring pin	4	ϕ 10x80
40	Bottom Idle sheave shaft	2	
41	Idle sheave	2	
42	Roller bearing	4	
43	Spring pin	4	ϕ 6x50
44	Bottom hook	1	
45	Hook latch	1	
46	Hook latch spring	1	
47	Hook latch nut	1	
48	Hook latch bolt	1	
49	Upper shaft	2	
50	Shaft stopper pin	4	
51	Split pin	4	ϕ 4x28
52	Thick spacer	7(5)	() in the case of width beam
53	Fixing spacer	3(6)	() in the case of width beam

SHB100 with chain container

Fig. No.	Part name	No. per hoist	Remarks
54	Thin spacer	11(9)	() in the case of width beam
55	-	-	
56	Name plate	1	
57	Name plate B	1	
58	Name plate C	1	
59	Load chain	1	
60	Hand chain	1	for Chain hoist
61	Hand chain	1	for Geared trolley
62	-	-	
63	-	-	
64	Chain container assembly	1	
65	Container sling fitting	2	
66	Container sling fitting bolt A	2	
67	Container sling fitting bolt B	2	
68	Slotted nut	4	L-M16
69	Split pin	4	ϕ 4x32
70	Collar	2	
71	Balancer	1	
72	Hexagon head bolt	4	M10x100x26
73	U nut	4	M10
74	Stopper collar	1	
75	Stopper	2	
76	Socket bolt	2	M8x25x25
77	Spring washer	2	2-M8
78	Bumper L	2	
79	Bumper R	2	
80	Hexagon head bolt	8	M16x45x45
81	Spring washer	8	2-M16
82	Nut	8	1-M16
83	Buffer	4	
84	Hexagon socket head cap screw	8	M10x30x30
85	Plain washer	8	M10 small
86	U nut	8	M10
87	Chain hoist	1	reference in a owner's manual for kito manual chain hoist