

Post Type Bushings Series 8171

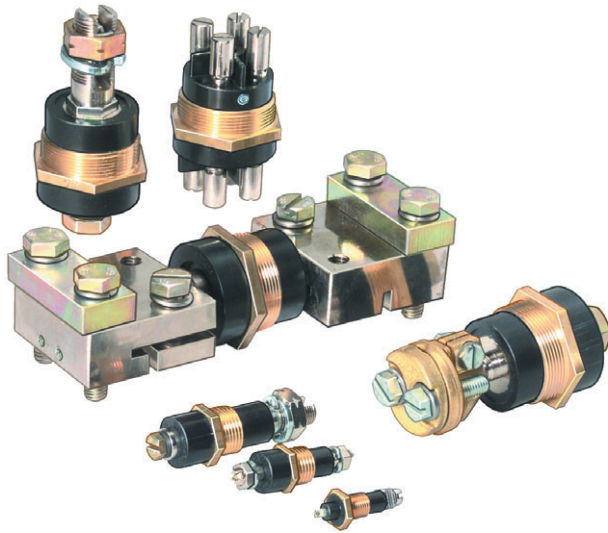

- > Means of supplying power to lead-in for Ex d enclosures
- > Sealed to prevent propagation of flame on explosion and insulated from wall
- > Versions with
 - split post connection
 - clamp connection
 - soldered connection
- > For voltages up to max. 1000 V and currents up to max. 630 A



03149E00

The bushings are permitted to be used as current feeders in enclosures with type of protection "flameproof". They are fitted puncture-proof and insulated into the enclosure wall. Duct bolt is located in the middle of a ring nut and the parts are bonded with a high-quality, track resistant insulating material (epoxy resin) to form an inseparable unit. For the connection points in the Ex e enclosure increased creepage paths and air gaps according to IEC/EN 60079-7 are valid. The bushings have to be secured against self-loosening.

	ATEX / IECEx					
Zone	0	1	2	20	21	22
For use in		x	x			

Post Type Bushings

Series 8171

Selection Table

Post type bushings

Rated cross section (flexible) [mm ²]	Number of studs	Current (post) [A]	Rated voltage [V]	Connector thread [mm]	Cross-section		Ordering code	Weight kg
					multi-strand [mm ²]	single-strand [mm ²]		
1	1	10	400	M10 x 1	Z: 2.5 L: 1.0	Z: 2.5 L: 1.5	8171/20-ZL	0.011
2,5	1	10	400	M10 x 1	Z: 2.5 G: 2.5 **)	Z: 2.5 G: 2.5 **)	8171/20-ZG	0.011
	1	26	400	M15 x 1.5	A: 2.5 L: 2.5	A: 2.5 L: 2.5	8171/17-AL	0.225
	1	54	400	M14 x 1.5	A: 2.5	A: 2.5	8171/15-AA	0.330
	1	54	630	M15 x 1.5	A: 2.5	A: 2.5	8171/02-AA	0.034
	1	54	630	M15 x 1.5	K: 2,5	K: 4	8171/01-KK	0.330
	6	17	400	M42 x 1.5	R: 4 L: 2,5	R: 6 L: 4	8171/06-RL	0.150
	1	54	800	M15 x 1.5	A: 2.5	A: 2.5	8171/42-AA	0.040
4	4	54	500	M42 x 1.5	R: 4	R: 6	8171/14-RR	0.195
6	1	54	800	M15 x 1.5	A: 2.5 B: 6 *)	A: 2.5 B: 6 *)	8171/43-AB	0.051
16	1	120	800	M20 x 1.5	A: 2.5 B: 10 *)	A: 4 B: 10 *)	8171/48-AB	0.140
25	1	250	1000	M42 x 1.5	K: 25 B: 35 *)	K: 35 B: 35 *)	8171/07-KB	0.350
35	1	250	1000	M42 x 1.5	K: 35 B: 35 *)	K: 50 B: 35 *)	8171/09-KB	0.700
70	1	200	1000	M42 x 1.5	C: 70 B: 120 *)	C: 95 B: 120 *)	8171/51-CB	0.520
150	1	250	1000	M42 x 1.5	D: 150 B: 150 *)	D: 150 B: 150 *)	8171/56-DB	0.530
240	1	630	1000	M42 x 1.5	Flachband max. 25 x 30 mm		8171/55-FF	1.800
Comments:					*) with cable lug			
					**) with cable lug thread M3			
					Type of connection in an Ex e enclosure		8171/...-□.	
					Type of connection in an Ex d enclosure		8171/...-□	
Further information on the different types of connection: see Terminals								
Earthing terminals								
Rated cross section (flexible) [mm ²]	Number of studs	Current (post) [A]	Rated voltage [V]	Connector thread [mm]	Max. conductor capacity		Ordering code	Weight kg
					flexible [mm ²]	single-wire or multiwire [mm ²]		
16	--	--	--	M20 x 1.5	16 50 *)	25 50 *)	8171/PE-16	0.140
50	--	--	--	M33 x 1.5	50 50 *)	70 50 *)	8171/PE-50	0.200
					*) with cable lug			

Post Type Bushings

Series 8171



Approvals

Marking

IECEX	Ex db eb II, Ex db eb I
Europe (ATEX)	II 2 G Ex db eb IIC Gb I M2 Ex db eb I Mb

Certificates

IECEX	IECEX PTB 06.0080U
Europe (ATEX)	PTB 00 ATEX 1066 U
Further certificates	Canada (CSA), Belarus (Gospromnadzor)

Technical Data

Electrical data

Rated operational voltage U_e	400, 500, 690, 1000 V, see selection table
Rated operational current I_e	max. 630 A, see selection table











Ambient conditions

Ambient temperature	- 55 ... + 130 °C
---------------------	-------------------

Mechanical data

Material		
Post terminal	8171/... 8171/55-FF, 8171/56-DB	brass copper
Insulating material	Epoxy resin	
Number of post terminal	1-, 4- and 6-pole	
Terminal capacity	Terminal capacity:	0.75 ... 300 mm ²
	Flat cable:	25 x 30 mm

Terminals

Design	Symbol	Description	Design	Symbol	Description
 07346E00	A	Hexagon head screw with spring washer and clamp	 07344E00	L	Solder socket
 07339E00	B	Cheese hd. or hex. hd. screw with spring washer (permissible only on Ex d side)	 07337E00	R	Cap or hood type terminal (round) on split post
 07342E00	C	Saddle clamp to DIN 46 223	 07341E00	Z	Cheese head screw with spring washer and clamp
 07343E00	K	Split post with hexagon nut and pressure plate DIN 22 412	 07340E00	F	Flat terminal
 07345E00	D	Terminal piece for cable bracket connection	 06790E00	G	Thread connector

E9

Post Type Bushings

Series 8171

Fitting

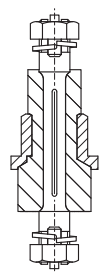

06367E00

Principles of construction

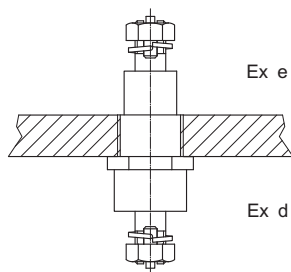

Mounting arrangement

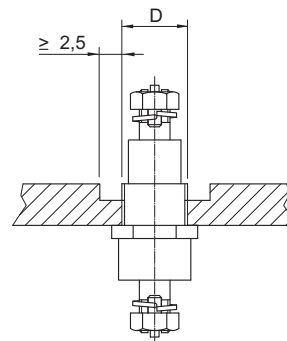

09143E00

09117E00

Illustration of creepages

Instructions for fitting the feed-through connectors:

When fitting feed-through connectors to a Flameproof protection type enclosure, the requirements of IEC/EN 60079-1 must be observed.

The number of threads available must be at least 5. If the enclosure volume is $\geq 100 \text{ cm}^3$, then the thread depth must be at least 8 mm.

The tapped holes into which the feed-through connectors will be screwed must fulfil the minimum requirements of Section 5.3, table 3.

The feed-through connectors are screwed in from the inside of the flameproof enclosure and must be prevented from rotating or unscrewing (e.g. with a locking plate or by gluing the threaded surface).

When screwing in the feed-through connectors, the specified tightening torques must be observed to avoid any damage. If necessary, use spacers to align the terminal positions.

Further, when fitting the feed-through connectors, the air gaps and tracking distances must be related to the rated voltage. If the sides of the enclosure are too thick, the tracking distances can be reduced to an impermissible value. This can be avoided by reducing the thickness of the enclosure side (see sketches).

Dimensional Drawings (All Dimensions in mm) - Subject to Alterations

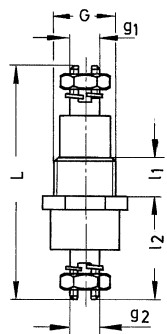

03642E00

8171/01-KK

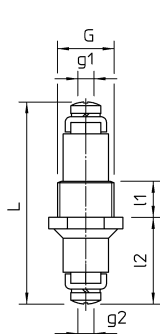

04526E00

8171/02-AA
8171/15-AA
8171/42-AA

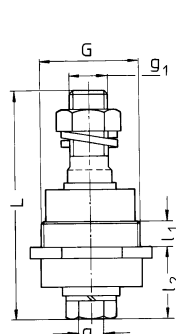

04624E00

8171/07-KB
8171/09-KB

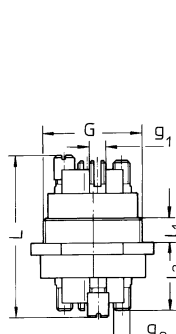

04625E00

8171/14-RR

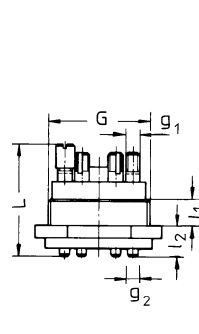

04626E00

8171/06-RL

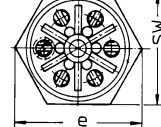
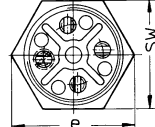
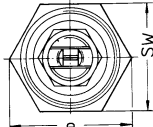
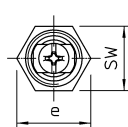
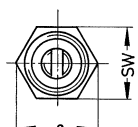

Post Type Bushings

Series 8171



Dimensional Drawings (All Dimensions in mm) - Subject to Alterations

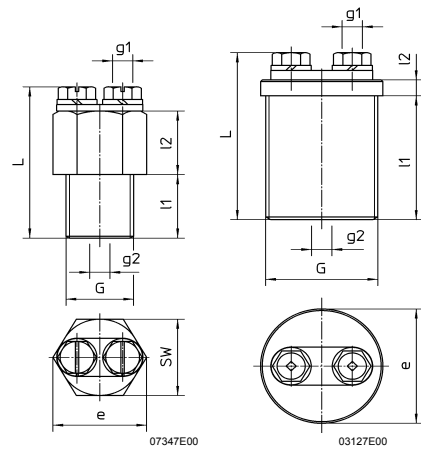
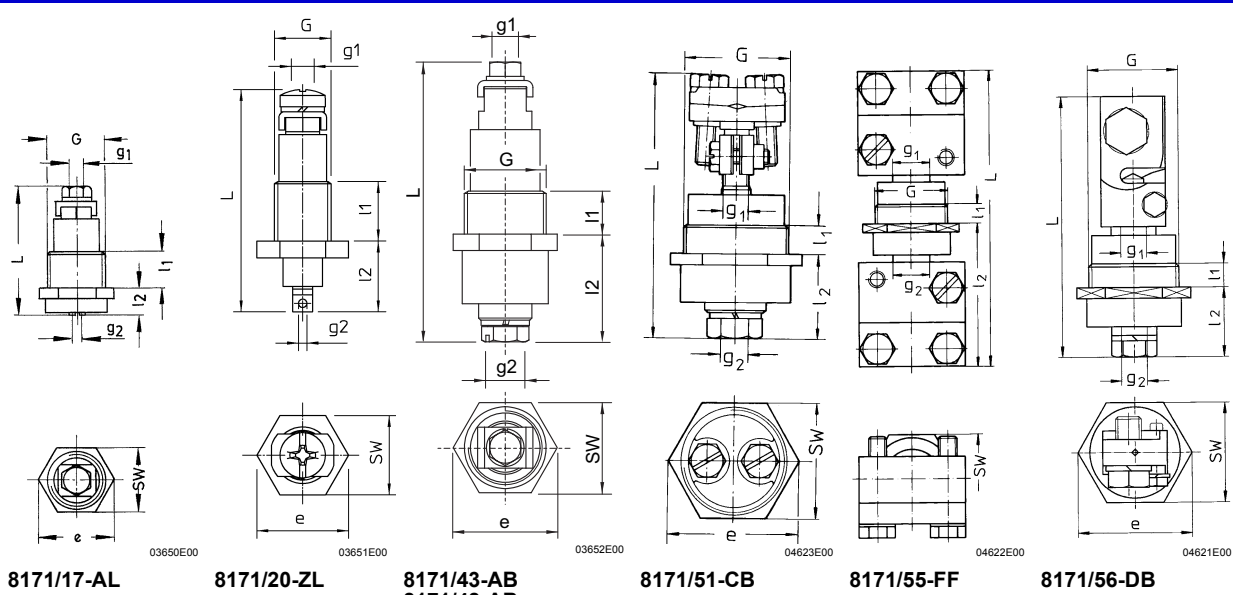

Type	L	l1	l2	G	g1	g2	e	SW
8171/01-KK	55.5	9.5	24.5	M15 x 1.5	M7 x 0.75	M7 x 0.75	19.6	17
8171/02-AA	53	9.5	23	M15 x 1.5	M4	M4	19.6	17
8171/06-RL	47	12.5	11	M42 x 1.5	M7 x 0.75	∅ 4.2	53.1	46
8171/07-KB	99.5	11	31.5	M42 x 1.5	S18 x 1.5	M12	53.1	46
8171/09-KB	106.5	11	31.5	M42 x 1.5	S22 x 1.5	M12	53.1	46
8171/14-RR	78.5	11	30	M42 x 1.5	M8.5 x 1	M8.5 x 1	53.1	46
8171/15-AA	49.5	13.5	19	M14 x 1.5	M4	M4	19.6	17
8171/17-AL	33	9.5	7	M15 x 1.5	M4	∅2.5	19.6	17
8171/20-ZL	39	10.5	12.5	M10 x 1	M4	∅ 1.5	16.2	14
8171/42-AA	63.5	9.5	29.5	M15 x 1.5	M4	M4	19.6	17
8171/43-AB	69.6	6.5	29.5	M15 x 1.5	M4	M5	19.6	17
8171/48-AB	68.3	10.5	26.3	M20 x 1.5	M5	M6	25.4	22
8171/51-CB	102	11	31.5	M42 x 1.5	M10 x 1	M12 x 1.75	53.1	46
8171/55-FF	175	11	84.5	M42 x 1.5	M20 x 2.5	M20 x 2.5	53.1	46
8171/56-DB	120	11	32	M42 x 1.5	M12 x 1.75	M12 x 1.75	53.1	46
8171/PE-16	47.6	20	27.6	M20 x 1.5	M6	M6	27.7	24
8171/PE-50	52.6	39	13.6	M33 x 1.5	M6	M6	47.3	41

We reserve the right to make alterations to the technical data, dimensions, weights, designs and products available without notice. The illustrations cannot be considered binding.