

# EEx-Telephone-Signal-Combination eFSK (Ex-Twin)

Optical and acoustic telephone call signalling device for use in areas with explosive atmospheres

- ▶ EEx II
- ▶ Protection degree IP 66
- ▶ Explosion-proof optical and acoustic signalling device
- ▶ ATEX-certified acc. to directive 94/9/EC
- ▶ Loud multitone bell
- ▶ Powerful strobe light



## Application

The eFSK 5842/1-EEx II is specifically designed for use as secondary telephone call indicator or signalling device in industrial applications with explosive atmospheres and may be used both indoors and outside.

The eFSK 5842/1-EEx II signalling device is suitable for both wall and ceiling mounting. The Twin-EEx II can be adjusted on to the following operating modes with a dip switch:

### Secondary telephone call indicator

In this mode the device is used for distinct signalling of incoming telephone calls in noisy environments. The signal is emitted loudly by the bell and additioned by the built-in strobe light. For this the strobe light is operated with call break bridging. The power supply for the optical and acoustic signals is fed from the 230 V mains. The signals are

controlled by the AC-call voltage. No signals are emitted in the event of a power failure.

### Signalling device

In this mode the device generates the acoustic and optical signals when the 230 V power supply is applied.

## Design

The device is a very compact unit comprising power supply, telephone connection, strobe light, amplifier and loudspeaker. The base is made of sea-water-proof cast aluminium and coated in plastic. The loudspeaker is made of impact and cold-resistant plastic and is mounted firmly on the housing. The cap of the strobe light forms the housing cover and is made of polycarbonate.

### Secondary telephone call indicator in a coating plant

The power supply for optical and acoustic signals comes from 230 V mains.



## Technical specifications

Housing	Aluminium die cast, polycarbonate
Protection degree	IP 66 (IEC 529)
Cable gland	1 x Pg 11 (230 V mains) } Standard 1 x Pg 9 (telephone circuit) } version (Version with metric thread on request)
Cable diameters	6–12 mm (230 V mains) 5–10 mm (telephone circuit)
Connection terminals	Cross section up to 1.5 mm <sup>2</sup> , single and fine wire
Operating position	Any (wall and ceiling mounting) In dusty rooms and/or rooms exposed to water, vertical, cable glands downwards.
Operating mode	1. Secondary telephone call indicator 2. Signalling device In secondary telephone call indicator mode with call break bridging.
Power supply connection	L1, N, PE (PE on housing) 230 VAC -15% / +10% / 50 Hz, 60 mA
Telephone connection	W, Lb 30 VAC to 90 VAC / 16 Hz to 54 Hz / 0 VDC to 63 VDC

<b>Acoustic signal</b>	Only with 230 V power supply
Signalling device	Loudspeaker
Signals	1-tone call / 2-tone call / 3-tone call
<b>Volume</b>	Approx. 90 dB(A), 1 m (Regarding volume specifications, please see the chapter "Technical Informations".)

<b>Optical signal</b>	Only with 230 V power supply
<b>Light source</b>	2 flash tubes, W approx. 0.9 joule
Flash frequency	1 Hz to 2 Hz

Temperature range	
Operation	-20° C to +40° C
Storage	-25° C to +70° C
Expl. protection class	II 2G EEx [ib] em IIC T6
Approval	PTB 99 ATEX 2115 BZT: D 130 879 J
Weight	Approx. 1.5 kg

### Terminals

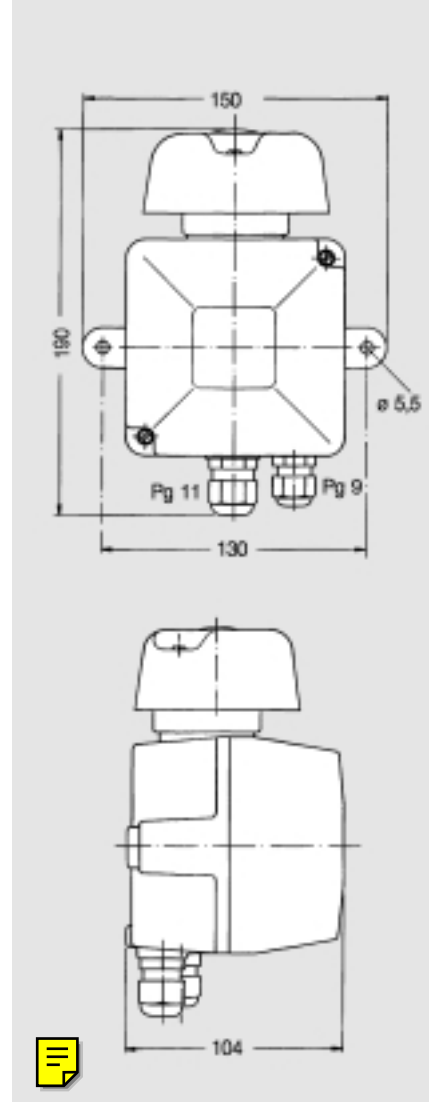
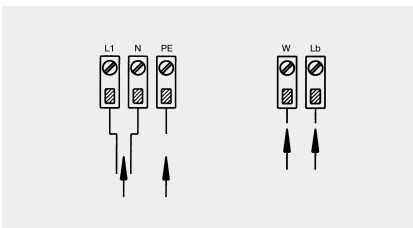

### Dip switch settings

Setting	Mode
	Secondary telephone call indicator
	Signalling device
Setting	Melody
	Three-tone 16.6 Hz
	Three-tone 50 Hz
	Three-tone 120 ms on / 50 ms off
	Three-tone 60 ms on / 25 ms off
	Two-tone 16.6 Hz
	Two-tone 50 Hz
	One-tone Continuous signal
	One-tone 120 ms on / 50 ms off

\* The full article number is made up by appending the colour code for the coloured cap to the article numbers given below.

<b>transp.</b>	01
<b>red</b>	02
<b>yellow</b>	03
<b>green</b>	04
<b>blue</b>	05

## Order information

Type	Name	Rated volt. V	Call voltage	Call frequency	Art.no.*
eFSK 5842/1	Optical and Acoustic Telephone Call Indicator	230 VAC	30–90 VAC	16 Hz...54 Hz	118 833 ..



