

Cen-Stat™ Static Grounding clamps, cables and reels



Static grounding systems like the Earth-Rite® range combine interlock control and visual indication to verified ground connection points and offer the highest levels of protection over electrostatic ignition risks. However, equipment specifiers may select passive grounding devices, like single pole clamps, to ground and bond plant equipment.

[Enquiry > Click here to submit a product related query or a request for quotation.](#)



When flammable or combustible products are being handled and processed in hazardous areas it is essential to specify certified equipment that will protect personnel from sources of electrostatic ignition.

Static grounding clamps that combine Factory Mutual & ATEX approvals are rigorously tested and certified to ensure they are capable of dissipating static charges from potentially charged equipment. This is especially significant when the equipment can be covered in coatings, product deposits or rust that is capable of preventing the clamp from making low resistance electrical contact with the equipment to be grounded.

Establishing a solid electrical connection can only be achieved by penetrating any connection

inhibitors like coatings, product deposits and rust. Factors like this will impede the dissipation of static charges from the object to ground if the clamp is not capable of penetrating them and making a connection to the base metal of the container or vessel. Once a strong connection is established, it is vital that this connection remains constant for the duration of the process operation.

Factory Mutual approved clamps undergo a series of mechanical and electrical tests to ensure they can function as reliable static grounding clamps in EX / HAZLOC areas.

ATEX certification ensures there are no sources of mechanical sparking, like thermite reactive materials such as aluminium, or sources of stored mechanical energy, present in the construction of the clamp.



Static grounding clamps must be capable of breaking through coatings, product deposits and rust to ensure a good electrical connection to process equipment.

Cen-Stat™ Static Grounding clamps, cables and reels

5 good reasons to specify ATEX & FM approved clamps.

- > **Clamp Pressure Testing**
ensures the grounding clamp is capable of establishing and maintaining low resistance electrical contact with equipment (FM approvals).
- > **Electrical Continuity Testing**
ensures the electrical continuity from the teeth throughout the grounding clamp is less than 1 ohm (FM approvals).
- > **High Frequency Vibration Testing**
ensures the grounding clamp is capable of maintaining positive contact when attached to vibrating equipment (FM approvals).
- > **Mechanical Pull Testing**
ensures the grounding clamp cannot be pulled off the equipment without an intentional application of force (FM approvals).
- > **Sources of mechanical sparking**
ensures no mechanical sparking sources are present in the clamp (ATEX certification).

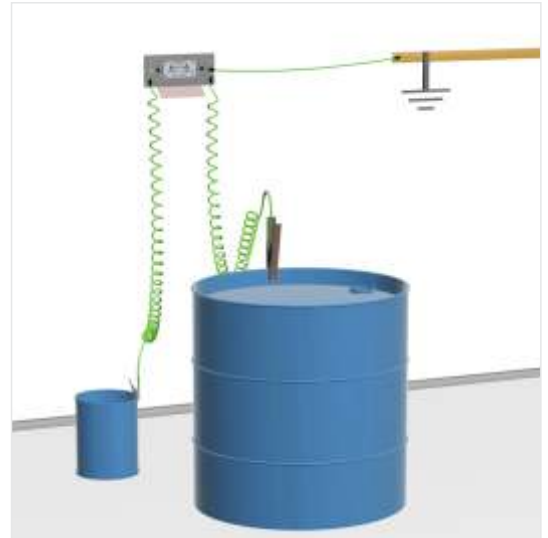

To remove static electricity from the EX/HAZLOC atmosphere grounding clamps should be capable of achieving connections to equipment with resistance values that do not exceed 10 ohms.

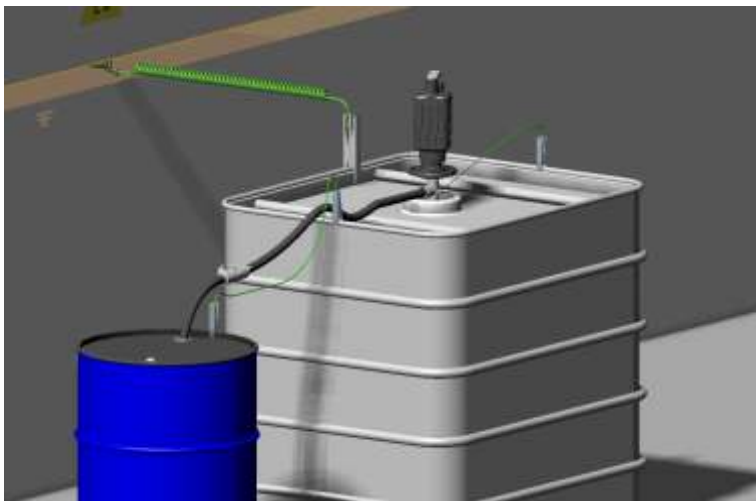

Equipment can only be grounded by ensuring a low resistance connection to verified true earth grounding points (e.g. copper bus-bars). Other equipment used in the process can be bonded to the equipment that is grounded ensuring static electricity does not accumulate on the equipment in the overall system.

Warning!

Drums and containers can have typical coating thicknesses of 675 micro-metres. Product deposits on drums and containers can result in thicknesses of up to several millimetres. The flat surfaces of basic welding clamps and battery clips are not designed to penetrate such coatings. It is of critical importance to specify clamps that can make regular and positive electrical contact with the conductive parts of the container. This will ensure that every time a process capable of generating static charges is carried out the risk of an incendive static spark discharge is reduced to an acceptable level.

Both IEC 60079-32-1, 13.4.1 and NFPA 77, 7.4.1.6 & 7.4.1.4 state:

Temporary connections can be made using bolts, pressure-type earth (ground) clamps, or other special clamps. Pressure-type clamps should have sufficient pressure to penetrate any protective coating, rust, or spilled material to ensure contact with the base metal with an interface resistance of less than 10 Ω*.

Where wire conductors are used, the minimum size of the bonding or earthing wire is dictated by mechanical strength, not by its current-carrying capacity. Stranded or braided wires should be used for bonding wires that will be connected and disconnected frequently.

*the underlined wording is additional wording present in IEC 60079-32-1.

Cen-Stat™ Static Grounding clamps, cables and reels

Static Grounding clamps with Cen-Stat cable

What is Cen-Stat™ cable?

Cen-Stat is a coating and conductor formula based on Newson Gale’s 30 plus years of experience of the rigorous demands of industrial work environments. It combines the features of a well-respected DuPont thermoplastic elastomer that provides a wide operating temperature range, resistance to a wide range of chemical products and enhanced mechanical durability.

The conductor is composed of multi-stranded galvanized steel threads providing a conductor cross-sectional area of 4 mm² (11 AWG), and with the coating included provides a cable diameter of 6 mm (0.25”). Cen-Stat is supplied in standard retractable spiral lengths of 3 m (10 ft.), 5 m (16 ft.), and 10 m (32 ft.). Cen-Stat is supplied with Newson Gale’s X45 and X90 heavy duty clamps. Other lengths are available on request.

Included in our Cen-Stat formulation is static dissipative material that prevents the cable from carrying an electrostatic charge and additives that provide protection against exposure to ultra-violet light.

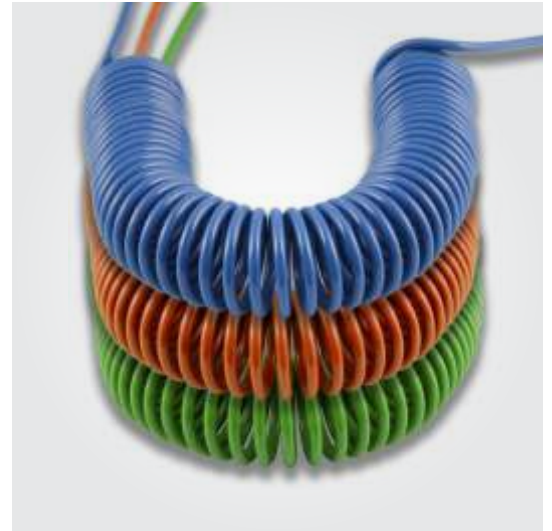

Cen-Stat cable

Cen-Stat cable is used across all Newson Gale product categories.

Blue Cen-Stat	Active grounding circuits carrying intrinsically safe current.
Green Cen-Stat	Passive grounding cable colour coded for Europe and the rest of the world.
Orange Cen-Stat	Passive grounding cable colour coded for North and South America.

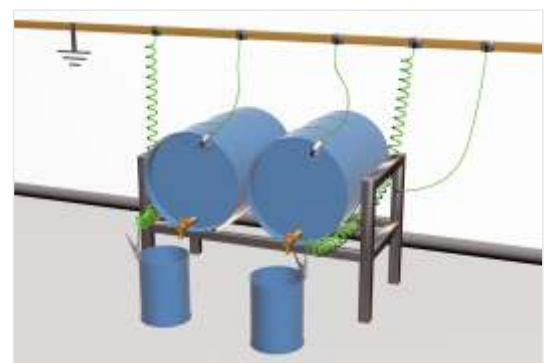
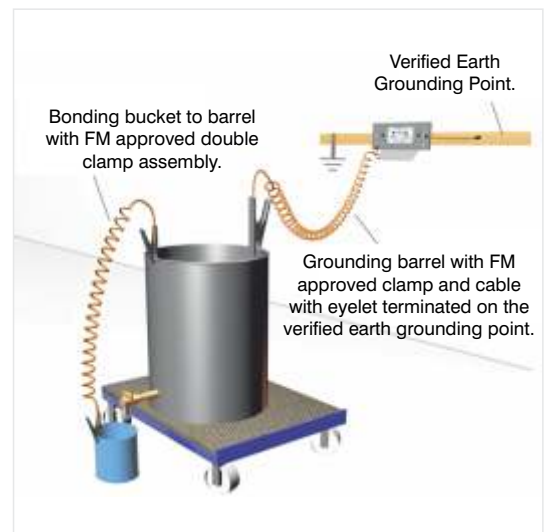

Cen-Stat™ Static Grounding clamps, cables and reels

VESX90 large Heavy Duty static grounding clamp with Cen-Stat cable

Applications:	Grounding and bonding metal objects ranging from 55 gallon drums to large metal totes and IBCs.
Clamp material:	Stainless Steel (SS grade: 304)
Operating Temperature:	-40°C to +60°C
Dimensions:	236 mm x 105 mm x 33 mm (9.3" x 4.1" x 1.3")
Maximum jaw opening:	30 mm (1.8") approx.
Clamp teeth:	2 tungsten carbide teeth - set side by side in a stainless steel mounting block for extra stability.
Spring:	Torsion spring (3.5 turn design) Stainless steel (SS Grade: 302).
FM /ATEX certification	Ex II 1 GD T6 (Assessed to EN 13463-1 : 2009) FM Certificate of Compliance number: 3046346. ATEX certificate number: Sira 02ATEX9381
Cable supplied:	3 m (10 ft.), 5 m (16 ft.) or 10 m (32 ft.) Cen-Stat spiral galvanized braided steel with green anti-UV / static dissipative Hytrel coating.
Wire diameter:	Conductor cross sectional area - 4 mm ² (11 AWG) approx. With Cen-Stat coating - 6 mm (0.25") diameter.
Ring terminal:	10 mm (0.4") hole diameter.



VESX45 standard size Heavy Duty static grounding clamp with Cen-Stat cable

Applications:	Grounding and bonding metal objects ranging from small cans to 55 gallon drums.
Clamp material:	Stainless Steel (SS grade: 304)
Operating Temperature:	-40°C to +60°C
Dimensions:	120 mm x 65 mm x 25 mm (4.7" x 2.6" x 1.0").
Maximum jaw opening:	15 mm (0.6") approx.
Clamp teeth:	2 tungsten carbide teeth - set side by side in a stainless steel mounting block for extra stability.
Spring:	Torsion spring (4 turn design) Stainless steel (SS Grade: 302).
FM /ATEX certification	Ex II 1 GD T6 (Assessed to EN 13463-1 : 2009) FM Certificate of Compliance number: 3046346. ATEX certificate number: Sira 02ATEX9381
Cable supplied:	3m (10 ft.), 5 m (16 ft.) or 10 m (32 ft.) Cen-Stat spiral galvanized braided steel with green anti-UV / static dissipative Hytrel coating.
Wire diameter:	Conductor cross sectional area - 4 mm ² (11 AWG) approx. With Cen-Stat coating - 6 mm (0.25") diameter.
Ring terminal:	10 mm (0.4") hole diameter.



Cen-Stat™ Static Grounding clamps, cables and reels

Heavy Duty grounding clamps with cable reels.

Retracting cable reels are an alternative solution to using retractable Cen-Stat™ spiral cable. They are normally specified for locations where there is a preference for ensuring process operators stow grounding clamps correctly for good “housekeeping” purposes when the clamps are not in use.

Newson Gale’s “R-series” of static grounding reels offer Hytrel cable housed on automatically retractable cable reel.

The R-series of retractable cable reels are supplied in 6.1 m (20 ft.), 9.1 m (30 ft.) and 15.2 m (50 ft.) lengths. The blue powder coated reel is supplied with Hytrel cable which has a yellow coating. The stainless steel reels are supplied with nylon coated stainless steel cable.



Blue powder coated retractable cables reels.

Applications:	Grounding and bonding metal objects ranging from small cans to 55 gallon drums (VESX45). Grounding and bonding metal objects ranging from open top 55 gallon drums to large totes and IBCs (VESX90).
Reel dimensions:	190 mm x 155 mm x 51 mm (7.5" x 6.1" x 2.0") approx.
Cable lengths:	6.1 m (20 ft.), 9.1 m (30 ft.), 15.2 m (50 ft.) with Hytrel coating.
Cable supplied	Hytrel multi-stranded galvanized steel with hi-viz yellow coating.
Cable diameter:	2.3 mm (3/32") galvanized braided cable conductor 3.2 mm (1/8") with Hytrel coating.
Reel construction:	Latchable spring mounted cable drum mounted in powder coated steel housing.
Reel FM / ATEX Certification:	FM approved (R20 & R30) ATEX Ex II 2 GD T6 (Assessed to EN 13463-1 : 2001).
Clamp FM / ATEX Certification:	FM approved. ATEX Ex II 1 GD T6 (Assessed to EN 13463-1 : 2009).



Cen-Stat™ Static Grounding clamps, cables and reels

Technical Information

NG Reels 20

	mm	inch	Mounting
A	190.00	7.48	
B	155.00	6.10	
C	6.750 x 9.53	0.27 x 0.38	2 slots
D	145.00	5.71	
E	170.00	6.69	
F	50.80	2.00	
Kgs	1.25		
lbs	2.75		

NG Reels 30

	mm	inch	Mounting
A	237.00	9.33	
B	200.00	7.87	
C	10.32	0.41	4 slots
D	200.00	7.87	
E	220.00	8.66	
F	60.00	2.36	
Kgs	2.25		
lbs	4.95		

NG Reels 50

	mm	inch	Mounting
A	237.00	9.33	
B	200.00	7.87	
C	10.32	0.41	4 slots
D	200.00	7.87	
E	220.00	8.66	
F	60.00	2.36	
Kgs	2.25		
lbs	4.95		

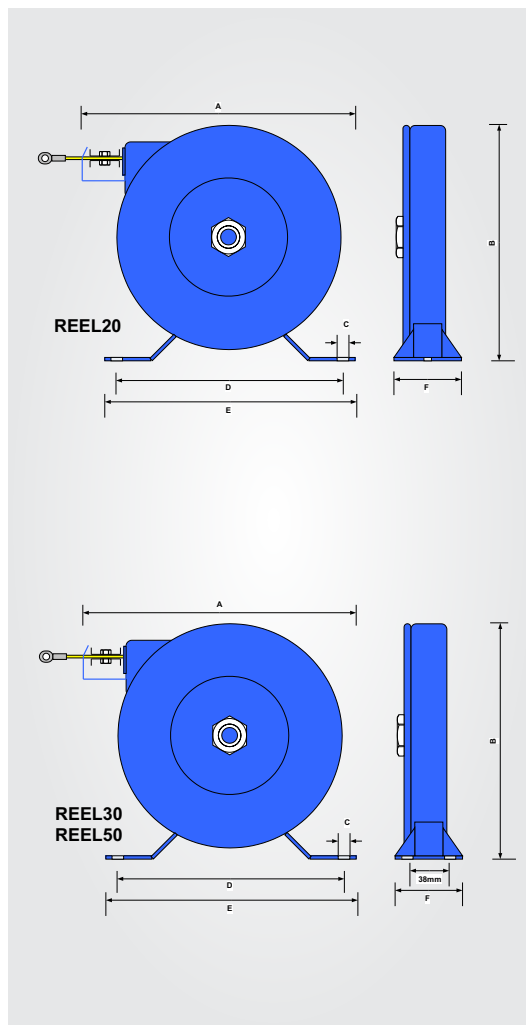

Cen-Stat™ Static Grounding clamps, cables and reels

R-Series stainless steel retractable cables reels.

Applications:	Grounding and bonding metal objects ranging from small cans to 55 gallon drums (VESX45). Grounding and bonding metal objects ranging from open top 55 gallon drums to large totes and IBCs (VESX90).
Reel dimensions:	190 mm x 155 mm x 51 mm (7.5" x 6.1" x 2.0") approx.
Cable lengths:	6.1 m (20 ft.), 9.1 m (30 ft.), 15.2 m (50 ft.) with Hytrel coating.
Cable supplied	Hytrel multi-stranded stainless steel (SS 304) with hi-viz yellow coating.
Cable diameter:	2.3 mm (3/32") stainless steel braided cable conductor 3.9 mm (5/32") with Hytrel coating.
Reel construction:	Latchable spring mounted cable drum mounted in stainless steel (SS 304) housing.
Reel FM / ATEX Certification:	FM approved (R20 & R30) ATEX Ex II 2 GD T6 (Assessed to EN 13463-1 : 2001).
Clamp FM / ATEX Certification:	FM approved. ATEX Ex II 1 GD T6 (Assessed to EN 13463-1 : 2009).



30 m (100 ft.) retractable cable reels

Applications:	Grounding and bonding metal objects ranging from small cans to 55 gallon drums (VESX45). Grounding and bonding metal objects ranging from open top 55 gallon drums to large totes and IBCs (VESX90).
Reel dimensions:	190 mm x 155 mm x 51 mm (7.5" x 6.1" x 2.0") approx.
Cable lengths:	30 m only (100 ft.).
Cable supplied	Hytrel multi-stranded galvanized steel with hi-viz yellow coating.
Cable diameter:	2.3 mm (3/32") galvanized braided cable conductor 3.2 mm (1/8") with Hytrel coating.
Reel construction:	Latchable spring mounted cable drum mounted in red powder coated housing (product code: VESM19). Non-latchable self retracting spring mounted cable drum mounted in red powder coated housing (product code: VESM21).
Reel ATEX Certification:	ATEX Ex II 2 GD T6 (Assessed to EN 13463-1 : 2001).
Clamp FM / ATEX Certification:	FM approved. ATEX Ex II 1 GD T6 (Assessed to EN 13463-1 : 2009).



Cen-Stat™ Static Grounding clamps, cables and reels

Additional static grounding devices in the Cen-Stat™ range.

Double ended VESX90

Applications:	Bonding metal objects ranging from 55 gallon drums to large metal totes and IBCs.
Clamp material:	Stainless Steel (SS grade: 304)
Operating Temperature:	-40°C to +60°C
Dimensions:	236 mm x 105 mm x 33 mm (9.3" x 4.1" x 1.3")
Maximum jaw opening:	30 mm (1.8") approx.
Clamp teeth:	2 tungsten carbide teeth - set side by side in a stainless steel mounting block for extra stability.
Spring:	Torsion spring (3.5 turn design) Stainless steel (SS Grade: 302).
FM /ATEX certification	Ex II 1 GD T6 (Assessed to EN 13463-1 : 2009) FM Certificate of Compliance number: 3046346. ATEX certificate number: Sira 02ATEX9381
Cable supplied:	3 m (10 ft.), 5 m (16 ft.) or 10 m (32 ft.) Cen-Stat spiral galvanized braided steel with green anti-UV / static dissipative Hytrel coating.
Wire diameter:	Conductor cross sectional area - 4 mm ² (11 AWG) approx. With Cen-Stat coating - 6 mm (0.25") diameter.

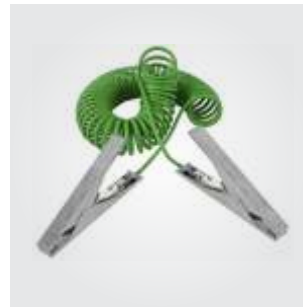

Double ended VESX45

Applications:	Bonding metal objects ranging from small cans to 205 litre (55 gallon) drums.
Clamp material:	Stainless Steel (SS grade: 304)
Operating Temperature:	-40°C to +60°C
Dimensions:	120 mm x 65 mm x 25 mm (4.7" x 2.6" x 1.0").
Maximum jaw opening:	15 mm (0.6") approx.
Clamp teeth:	2 tungsten carbide teeth - set side by side in a stainless steel mounting block for extra stability.
Spring:	Torsion spring (4 turn design) Stainless steel (SS Grade: 302).
FM /ATEX certification	Ex II 1 GD T6 (Assessed to EN 13463-1 : 2009) FM Certificate of Compliance number: 3046346. ATEX certificate number: Sira 02ATEX9381
Cable supplied:	3m (10 ft.), 5 m (16 ft.) or 10 m (32 ft.) Cen-Stat spiral galvanized braided steel with green anti-UV / static dissipative Hytrel coating.
Wire diameter:	Conductor cross sectional area - 4 mm ² (11 AWG) approx. With Cen-Stat coating - 6 mm (0.25") diameter.

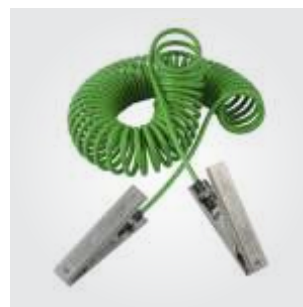

Cen-Stat™ Static Grounding clamps, cables and reels

Additional options



Stainless steel swivel for mounting R20, R30 and R50 reels.



C-Clamp 20 mm x 48 mm x 37 mm (0.80" x 1.90" x 1.46") Tamper proof version available.



Clamp storage station with earth ground terminals. Stows two grounding clamps.



Nylon coated stainless steel cable connected to VESX45 and VESX90 grounding clamps.

What are the benefits of using tungsten carbide teeth?

Tungsten carbide is one of the hardest materials in use in industry today and when used in combination with a well designed clamp spring, has the capability to continuously bite through coatings, rust or product deposits that a basic alligator clip or welding clamp would struggle with. Sharpened tungsten carbide teeth are a standard feature of Newson Gale's heavy duty clamps.

Why is spring design so important?

A grounding clamp's effectiveness at protecting against the ignition of flammable atmospheres should not be judged by how difficult it is to open the clamp handles - that is the result of a poorly designed spring and clamp assembly. A well designed spring and clamp assembly should enable an operator to apply a reasonable amount of torque to open the clamp without causing stress to their hand.

The most important thing to know is what pressure is applied at the business end, i.e. where the clamp teeth are trying to make a solid electrical connection to the equipment at risk of static charging. The combination of spring material, spring diameter, the number of active spring coils and the length of the spring legs have all been factored into Newson Gale grounding clamps to balance operator ergonomics with a clamping force that can match and exceed the testing requirements of Factory Mutual.



Tungsten carbide teeth are designed to penetrate electrical impedances caused by rust, coatings and product deposits.



Newson Gale springs are designed and analysed with the aid of Finite Element Analysis technologies.

Cen-Stat™ Static Grounding clamps, cables and reels

Contact Us > Your enquiry will be processed rapidly via our webform enquiry service. If you would prefer to call us, or e-mail us, please use the contact details provided below.

Product Ordering Codes

Product Codes	Product Description
VESX45/1G03	VESX45 standard size heavy duty clamp with 3 m (10 ft.) Cen-Stat spiral cable.
VESX45/1G05	VESX45 standard size heavy duty clamp with 5 m (16 ft.) Cen-Stat spiral cable.
VESX45/1G10	VESX45 standard size heavy duty clamp with 10 m (32 ft.) Cen-Stat spiral cable.
VESX90/1G03	VESX90 large heavy duty clamp with 3 m (10 ft.) Cen-Stat spiral cable.
VESX90/1G05	VESX90 large heavy duty clamp with 5 m (16 ft.) Cen-Stat spiral cable.
VESX90/1G10	VESX90 large heavy duty clamp with 10 m (32 ft.) Cen-Stat spiral cable.
VESX45/1G03/X45	Doubled ended VESX45 assembly with 3 m (10 ft.) of Cen-Stat spiral cable.
VESX90/1G03/X90	Doubled ended VESX90 assembly with 3 m (10 ft.) of Cen-Stat spiral cable.
VESC41	Stainless steel C-Clamp (SS 304). Add H for optional Hex head nut and bolt.
Other configurations	If you require clamp and cable configurations not covered by the codes above contact us to discuss your requirements.
VESX45/R20	Blue coated 6.1 m (20 ft.) cable reel with X45 standard size heavy duty clamp.
VESX45/R30	Blue coated 9.1 m (30 ft.) cable reel with X45 standard size heavy duty clamp.
VESX45/R50	Blue coated 15.2 m (50 ft.) cable reel with X45 standard size heavy duty clamp.
VESX90/R20	Blue coated 6.1 m (20 ft.) cable reel with X90 large heavy duty clamp.
VESX90/R30	Blue coated 9.1 m (30 ft.) cable reel with X90 large heavy duty clamp.
VESX90/R50	Blue coated 15.2 m (50 ft.) cable reel with X90 large heavy duty clamp.
Stainless Steel R-Series reels	To specify a stainless steel reel place the code "SS" after the reel size, e.g. for a 6.1 m (20 ft.) stainless steel reel with an X45 clamp specify: VESX45/R20SS.
VESM19	Latchable self retracting 30 m (100 ft.) Hytrel coated galvanised steel cable. Order the VESM21 for the non-latchable variant.
Swivel mount	Stainless Steel swivel mount permits reel to rotate about a 130° arc. REEL/SM/20 for 6.1 m (20 ft.) reels. REEL/SM/30 for 9.1 m (30 ft.) reels. REEL/SM/50 for 15.2 m (50 ft.) reels.

United Kingdom
Newson Gale Ltd
Omega House
Private Road 8
Colwick, Nottingham
NG4 2JX, UK
+44 (0)115 940 7500
groundit@newson-gale.co.uk

Deutschland
Newson Gale GmbH
Ruhrallee 185
45136 Essen
Deutschland
+49 (0)201 89 45 245
erdung@newson-gale.de

United States
IEP Technologies, LLC
417-1 South Street
Marlborough, MA 01752
USA
+1 732 961 7610
groundit@newson-gale.com

South East Asia
Newson Gale S.E.A. Pte Ltd
136 Joo Seng Road, #03-01
Singapore
368360
+65 6704 9461
ngsea@newson-gale.com