



AIR HOIST

# JDN MINI FOOD GRADE

Clean – Reliable – Durable  
The new benchmark in the  
food industry



**J·D·NEUHAUS**  
1745 permanent excellence

# CUSTOMIZED FOR THE FOOD INDUSTRY

In the food industry, hygiene comes first. We know that from our dialog with longtime clients. That's why we have developed a special Food Grade model for our JDN Mini Air Hoist specifically for use in this industry. The JDN Mini Food Grade meets the hygienic requirements and perfectly complements the HACCP plan devised by companies in the food and beverage industry.

Its compressed air function and cooling with compressed exhaust eliminate costly downtime: the JDN Mini Food Grade is 100% available and ready for use 24/7.

With its motor housing made of uncoated cast aluminum and its chain, chain guide, load sleeve, and hooks made from stainless steel, it is impervious to high humidity, water, dirt, and corrosion. Intensive

cleaning is uncomplicated – even with a high-pressure washer. A definite plus for everyday hygienic processes.

The JDN Mini Food Grade only requires minor maintenance and its low cost ensures optimal TCO. At the end of its operational life, all the components of the JDN Mini can be recycled. Nonetheless, we naturally offer our 360° service partnership and are continuously refining the Mini – in keeping with the needs of your industry.

**In short: we are keeping our promise to you of permanent excellence.**

”

*With all its complexity, the food industry was new territory for us at first.*

*But the feedback from the global market showed us that we are moving in the right direction with the JDN Mini Food Grade.*

## J.D. NEUHAUS – MORE THAN PRODUCTS

The permanent excellence that we have demanded of ourselves for over 275 years as a family business now in its seventh generation, can only be achieved with a commitment to clear values.

The three pairs of values of tradition and innovation, performance and durability, and partnership and passion form the cornerstone for our daily conduct. They shape our partnership with the people who work for us as well as with our partners and clients. They can be found in the

quality and the German engineering of our products and in the way we work with you and find new solutions thanks to our innovative spirit.

Our thinking is therefore pervaded by sustainability, which we believe our tomorrow deserves and needs.





# PRODUCT BENEFITS AND ADVANTAGES

As a food manufacturer, the JDN Mini's Food Grade model expands your appliance portfolio with a reliable, efficient tool with real benchmark qualities. The Food Grade is mechanical and pneumatically driven. We completely dispense with electrical components and thereby eliminate the risk of salt bridges or short circuits entirely – essential for minimizing the risk of downtime. Moreover, the JDN hoist's pneumatic drive and its ATEX class 2 make it the best suited for use in the explosion-risk area (e.g., powdered milk, flour, or coffee).

With its maximum carrying capacity of 980kg and high lifting and lowering speeds, the JDN Mini Food Grade benefits from its stepless control. It can be used at operating temperatures between -20° and +50°C.

The Food Grade's motor lubrication is similarly optimized for use in food production. For this, we use a food grade lubricant with the H1 certification that HACCP regulations require. The chain lubricant also meets this standard.

Another aspect that is important for hygienic processes is resistance to water and other cleaning agents. This, combined with its imperviousness to high humidity, cold, and heat, make the JDN Mini Food Grade ideal for the food industry's demands.

We have made our sustainability ideas a reality with the JDN Mini Food Grade due to its minimal energy expenditure and the complete recyclability of all its components. Thanks to a free service app for maximum information transparency, the rarely needed on-site maintenance is faster, simpler, and more cost-effective.

## **PNEUMATIC**

*mechanical drive*

---

## **IMPERVIOUS**

*to high humidity*

---

## **CLEANABLE**

*with abrasive cleaners*

---

## **24/7 AVAILABLE**

*100% ready for use*

---

## **COST-EFFICIENT**

*very easy servicing*

# AIR HOIST MINI

## TECHNICAL DATA

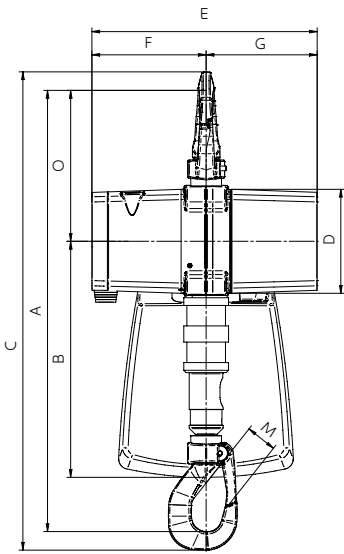

TYPE	UNIT	MINI 125	MINI 250	MINI 500	MINI 1000
Air pressure	bar	6	6	6	6
Carrying capacity	kg	125	250	500	980
Lifting speed with full load	m/min	20	10	12,5	6,3
Lifting speed without load	m/min	40	20	20	11,5
Lowering speed with full load	m/min	40	20	20	12
Lowering speed without load	m/min	25	12,5	13	7,5
Air consumption with full load – lifting	m <sup>3</sup> /min	0,95	0,95	1,7	1,7
Air consumption with full load – lowering	m <sup>3</sup> /min	0,95	0,95	1,7	1,7
Air connection	–	G ½	G ½	G ½	G ½
Hose size (ø interior)	mm	13	13	13	13
Weight for 5 m lift and 4 m control length	kg	11	11	21,5	22
Chain size	mm	4,7 x 14,1	4,7 x 14,1	7,4 x 22	7,4 x 22
Lifting height	m	5	5	5	5
Control length	m	4	4	4	4
Noise level with full load – lifting*	dB (A)	78	78	78	78
Noise level with full load – lowering*	dB (A)	80	80	80	80
ATEX zone	–	2/22	2/22	2/22	2/22
* Mechanism group/life cycle	h	1 Am/800	1 Am/800	1 Am/800	1 Am/800

\*Measured from 1 m distance in accordance with DIN 45635 Part 20. Power value at room temperature.  
Subject to change without notice.

